

Ruijie Reyee RG-ES105D, ES105GD, ES108D, ES108GD

Installation Guide

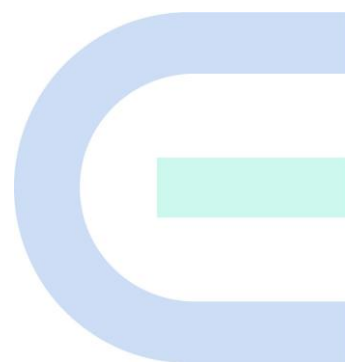

Copyright

Copyright © 2025 Ruijie Networks

All rights are reserved in this document and this statement.

Without the prior written consent of Ruijie Networks, no organization or individual is permitted to reproduce, extract, back up, modify, or distribute the content of this document in any manner or form. It is also prohibited to translate the document into other languages or use any or all parts of it for commercial purposes.

 and other Ruijie networks logos are trademarks of Ruijie Networks.

All other trademarks or registered trademarks mentioned in this document are owned by their respective owners.

Disclaimer

The products, services, or features that you purchase are subject to commercial contracts and terms. It is possible that some or all of the products, services, or features described in this document may not be available for purchase or use. Unless agreed upon otherwise in the contract, Ruijie Networks does not provide any explicit or implicit statements or warranties regarding the content of this document.

The names, links, descriptions, screenshots, and any other information regarding third-party software mentioned in this document are provided for your reference only. Ruijie Networks does not explicitly or implicitly endorse or recommend the use of any third-party software and does not make any assurances or guarantees concerning the applicability, security, or legality of such software. You should choose and use third-party software based on your business requirements and obtain proper authorization. Ruijie Networks assumes no liability for any risks or damages arising from your use of third-party software.

The content of this document is subject to constant change due to product version upgrades or other reasons. Thus, Ruijie Networks reserves the right to modify the content of the document without prior notice or prompt.

This manual serves solely as a user guide. While Ruijie Networks endeavors to ensure the accuracy and reliability of the content when compiling this manual, it does not guarantee that the content of the manual is free of errors or omissions. All information contained in this manual does not constitute any explicit or implicit warranties.

Preface

Intended Audience

This document is intended for:

- Network engineers
- Technical support and servicing engineers
- Network administrators

Technical Support

- Ruijie Reye website: <https://reyee.ruijie.com>
- Online support center: <https://reyee.ruijie.com/en-global/support>
- Case portal: <https://www.ruijie.com/support/caseportal>
- Community: <https://community.ruijie.com>
- Email support: service_rj@ruijie.com
- Live chat: <https://reyee.ruijie.com/en-global/rita>

Conventions

1. Signs

The signs used in this document are described as follows:

 **Danger**
An alert that calls attention to safety instruction that if not understood or followed can result in personal injury.

 **Warning**
An alert that calls attention to important rules and information that if not understood or followed can result in data loss or equipment damage.

 **Caution**
An alert that calls attention to essential information that if not understood or followed can result in function failure or performance degradation.

 **Note**
An alert that contains additional or supplementary information that if not understood or followed will not lead to serious consequences.

 **Specification**
An alert that contains a description of product or version support.

2. Notes

This manual provides installation steps, troubleshooting, technical specifications, and usage guidelines for cables and connectors. It is intended for users who want to understand the above and have extensive experience in network deployment and management, and assume that users are familiar with related terms and concepts.

Contents

Preface	1
1 Product Overview	3
1.1 RG-ES105D	3
1.2 RG-ES105GD	6
1.3 RG-ES108D	9
1.4 RG-ES108GD	12
2 Preparation Before Installation.....	15
2.1 Safety Suggestions	15
2.1.1 Installation	15
2.1.2 Movement	15
2.1.3 Electricity	16
2.1.4 Static Discharge Damage Prevention.....	16
2.2 Installation Site Requirements	17
2.2.1 Ventilation.....	17
2.2.2 Temperature and Humidity.....	17
2.2.3 Cleanness	17
2.2.4 Grounding	18
2.2.5 Lightning Resistance.....	19
2.2.6 EMI	20
2.3 Installation Tools.....	20
3 Product Installation.....	21
3.1 Installation Flowchart	21
3.2 Precautions Before Installation	21

3.3 Installing the RG-ES100	22
3.3.1 Mounting a Switch Against a Wall.....	22
3.3.2 Mounting the Switch on a Table.....	23
3.4 Checking After Installation	23
4 System Commissioning.....	24
4.1 Startup Check	24
4.1.1 Checking Before the Device Is Powered On	24
4.1.2 Checking After Program Startup (Recommended).....	24
5 Maintenance and Troubleshooting.....	25
5.1 Troubleshooting Procedure	25
5.2 Troubleshooting Common Faults	25
6 Appendix A Connectors and Connection Media	26
7 Appendix B Site Selection	27
8 Appendix C Surge Protection	28
9 Appendix D Cabling Recommendations in Installation.....	31

1 Product Overview

The RG-ES100 series switch includes the following models.

Model	10/100 Base-T Auto-sensing Ethernet Port	10/100/1000 Base-T Auto-sensing Ethernet Port	1000Base-X SFP Port	Console Port
RG-ES105D	5	N/A	N/A	N/A
RG-ES108D	8	N/A	N/A	N/A
RG-ES105GD	N/A	5	N/A	N/A
RG-ES108GD	N/A	8	N/A	N/A

Caution

1000Base-T is backward compatible with 100Base-T and 10Base-T.

1.1 RG-ES105D

Technical Specifications

Model	RG-ES105D
Ports	Five 10/100Base-TX Ethernet ports
Power Supply	<ul style="list-style-type: none"> ● AC input Rated voltage range: 100 V AC to 240 V AC Maximum voltage range: 90 V AC to 264 V AC Frequency: 50/60 Hz Rated current: 0.3 A ● Adapter output Rated voltage range: 5 V DC Rated current range: 1 A
EEE	Not supported
PoE	Not supported
Power Consumption	5 W
Operating Temperature	0°C to 40°C (32°F to 104°F)

Model	RG-ES105D
Storage Temperature	-40°C to +70°C (-40°F to +158°F)
Operating Humidity	10% to 90% RH
Storage Humidity	5% to 95% RH
Number of Fans	Fanless
Temperature Warning	Not supported
Accessing Optical Module Information	Not supported
Certification	CE
Earth Leakage Current	≤ 1.5 mA
Dimensions (W x D x H)	119 mm x 75 mm x 24 mm (4.69 in. x 2.95 in. x 0.94 in.)
Net Weight	0.25 kg (0.55 lbs)

! Warning

Operation of this equipment in a residential environment could cause radio interference.

Product Appearance

On the front panel, the RG-ES105D Ethernet switch provides five 10/100Base-TX Ethernet ports and one DC power port.

Figure 1-1 Appearance of the RG-ES105D

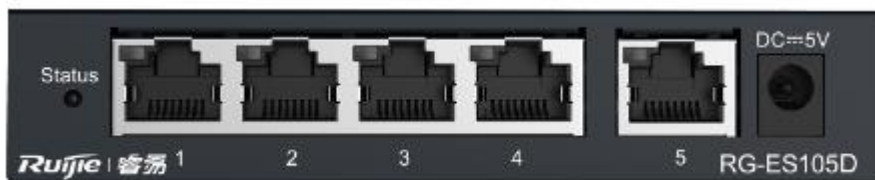

Front Panel

Figure 1-2 Front Panel of the RG-ES105D

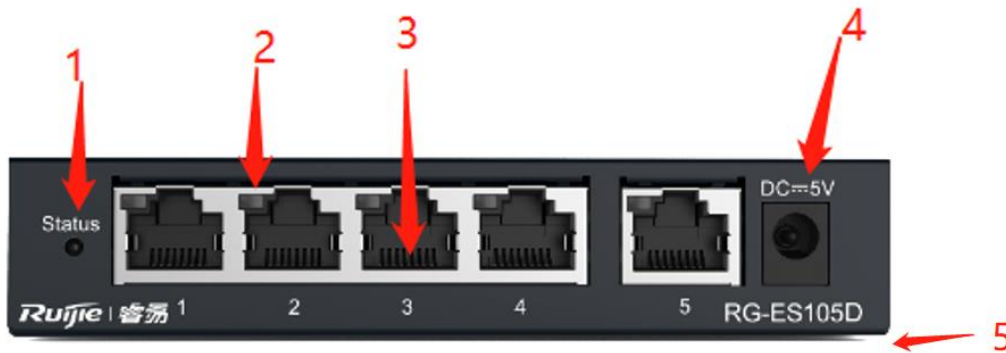

Note:	<ol style="list-style-type: none"> 1. System status LED 2. Port status LED 3. 10/100Base-TX Ethernet port 4. DC power port 5. Nameplate on the bottom of the device
-------	--

Back Panel

Figure 1-3 Back Panel of the RG-ES105D



Note:	<ol style="list-style-type: none"> 1. Grounding hole
-------	---

Heat Dissipation

The RG-ES105D adopts natural heat dissipation, thereby ensuring normal operation. You must maintain a minimum clearance of 100 mm (3.94 in.) around the RG-ES105D. It is recommended that you clean the RG-ES105D once every three months to avoid dust from blocking vents.

LEDs

LED	Panel Identification	State	Meaning
	Status	Off	The switch is powered off.

LED	Panel Identification	State	Meaning
System status LED		Solid green	The switch is operational.
RJ45 port status LED	1-5	Off	The port is not connected.
		Solid green	The port is connected at a rate of 10/100 Mbps.
		Blinking green	The port is receiving or sending traffic at a rate of 10/100 Mbps.

1.2 RG-ES105GD

Technical Specifications

System Specifications	Flash memory	1 MB
	Forwarding rate	7.44 Mpps
	Switching capacity	10 Gbps(bit/s)
Port Specifications	Total number of RJ45 ports	5
	Number of 10/100/1000BASE-T ports	5
Power Supply and Consumption	Power input	DC adapter: <ul style="list-style-type: none"> ● Rated input voltage: 100 V AC to 240 V AC, 50 Hz to 60 Hz ● Maximum input voltage: 90 V AC to 264 V AC, 47 Hz to 63 Hz ● Rated input current: 0.3 A Output: <ul style="list-style-type: none"> ● Rated output voltage: 5 V DC ● Maximum output current: 1 A
	Maximum power consumption	5 W
	Power supply	DC power adapter
Dimensions and Weight	Casing	Metal
	Product dimensions (W x D x H)	119 mm x 75 mm x 24 mm (4.69 in. x 2.95 in. x 0.94 in.)
	Weight	250 g (0.55 lbs) (without packaging materials)
	Shipping weight	0.47 kg (1.04 lbs)

Environment and Reliability	Fan	Fanless design
	Cooling	Natural cooling
	Mounting options	Desk
	Hot swapping of cables	Hot swapping supported by the service port and power connector
	MTBF	200,000 hours
	Operating temperature	0°C to 40°C (32°F to 104°F)
	Storage temperature	-40°C to +70°C (-40°F to +158°F)
	Operating humidity	10% RH to 90% RH (non-condensing)
	Storage humidity	5% RH to 95% RH (non-condensing)
	Altitude	<ul style="list-style-type: none"> ● Operating altitude: -500 m to +5,000 m (-1,640.42 ft. to +16,404.20 ft.) ● Storage altitude: -500 m to +5,000 m (-1,640.42 ft. to +16,404.20 ft.)
	ESD protection	<ul style="list-style-type: none"> ● Air discharge: 8 kV ● Contact discharge: 6 kV
	Surge protection	<ul style="list-style-type: none"> ● Service port: ±4 kV for common mode ● Power connector: ±2 kV for common mode and ±1 kV for differential mode
Earth Leakage Current	≤ 1.5 mA	
Certification and Regulatory Compliance	EMC	EN 55032 EN 61000-3-2 EN 61000-3-3 EN 55035 EN 300 386
	Safety compliance	EN 62638-1
	Certification	CE

 **Warning**

Operation of this equipment in a residential environment could cause radio interference.

Product Appearance

On the front panel, the RG-ES105GD Ethernet switch provides five 10/100/1000Base-T Ethernet ports and one DC power port.

Figure 1-4 Appearance of the RG-ES105GD

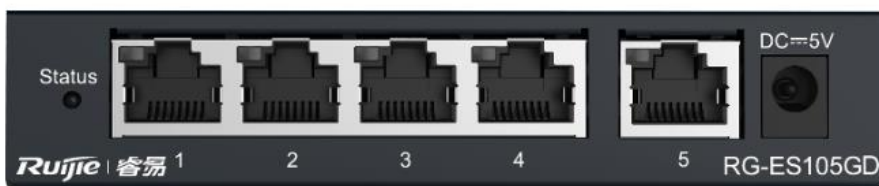

Front Panel

Figure 1-5 Front Panel of the RG-ES105GD

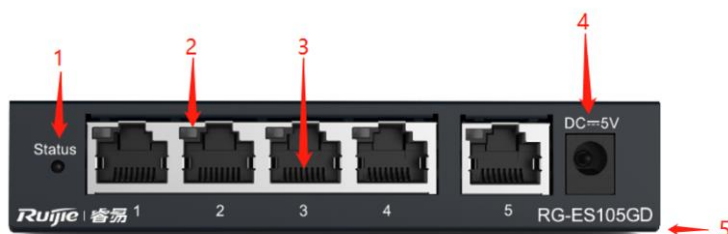

Note:	<ul style="list-style-type: none">1. System status LED2. Port status LED3. 10/100/1000Base-T Ethernet port4. DC power port5. Nameplate on the bottom of the device
-------	--

Back Panel

Figure 1-6 Figure 1-6 Back Panel of the RG-ES105GD



Note:	<ul style="list-style-type: none">1. Grounding hole
-------	---

Heat Dissipation

The RG-ES105GD adopts natural heat dissipation, thereby ensuring normal operation. You must maintain a minimum clearance of 100 mm (3.94 in.) around the RG-ES105GD. It is recommended that you clean the RG-ES105GD once every three months to avoid dust from blocking vents.

LEDs

LED	Panel Identification	State	Meaning
System status LED	Status	Off	The switch is powered off.
		Solid green	The switch is operational.
RJ45 port status LED	1-5	Off	The port is not connected.
		Solid green	The port is connected at a rate of 10/100/1000 Mbps.
		Blinking green	The port is receiving or sending traffic at a rate of 10/100/1000 Mbps.

1.3 RG-ES108D

Technical Specifications

Model	RG-ES108D
Ports	Eight 10/100Base-TX Ethernet ports
Power Supply	<ul style="list-style-type: none"> ● AC input Rated voltage range: 100 V AC to 240 V AC Maximum voltage range: 90 V AC to 264 V AC Frequency: 50/60 Hz Rated current: 0.3 A ● Adapter output Rated voltage range: 5 V DC Rated current range: 1 A
EEE	Not supported
PoE	Not supported
Power Consumption	5 W
Operating Temperature	0°C to 40°C (32°F to 104°F)

Storage Temperature	-40°C to +70°C (-40°F to +158°F)
Operating Humidity	10% to 90% RH
Storage Humidity	5% to 95% RH
Number of Fans	Fanless
Temperature Warning	Not supported
Accessing Optical Module Information	Not supported
Certification	CE
Earth Leakage Current	≤ 1.5 mA
Dimensions (W x D x H)	160 mm x 62 mm x 24 mm (6.30 in. x 2.44 in. x 0.94 in.)
Net Weight	0.35 kg (0.77 lbs)

! Warning

Operation of this equipment in a residential environment could cause radio interference.

Product Appearance

On the front panel, the RG-ES108D Ethernet switch provides eight 10/100Base-TX Ethernet ports and a DC power port.

Figure 1-7 Appearance of the RG-ES108D



Front Panel

Figure 1-8 Front Panel of the RG-ES108D

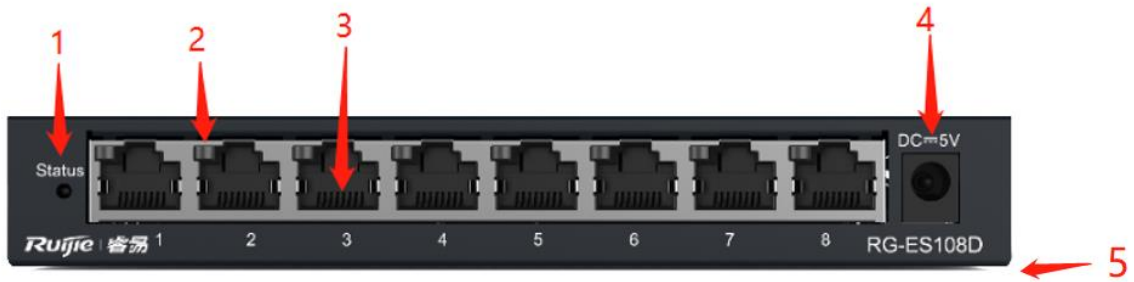

Note:	<ol style="list-style-type: none"> 1. System status LED 2. Port status LED 3. 10/100Base-TX Ethernet port 4. DC power port 5. Nameplate on the bottom of the device
-------	--

Back Panel

Figure 1-9 Back Panel of the RG-ES108D



N o t e :	<ol style="list-style-type: none"> 1. Grounding hole
-----------------------	---

Heat Dissipation

The RG-ES108D adopts natural heat dissipation, thereby ensuring normal operation. You must maintain a minimum clearance of 100 mm (3.94 in.) around the RG-ES108D. It is recommended that you clean the RG-ES108D once every three months to avoid dust from blocking vents.

LEDs

LED	Panel Identification	State	Meaning
System status LED	Status	Off	The switch is powered off.
		Solid green	The switch is operational.
RJ45 port status LED	1-8	Off	The port is not connected.
		Solid green	The port is connected at a rate of 10/100 Mbps.
		Blinking green	The port is receiving or sending traffic at a rate of 10/100 Mbps.

1.4 RG-ES108GD**Technical Specifications**

System Specifications	Flash memory	1 MB
	Forwarding rate	11.90 Mpps
	Switching capacity	16 Gbps(bit/s)
Port Specifications	Total number of RJ45 ports	8
	Number of 10/100/1000BASE-T ports	8
Power Supply and Consumption	Power input	DC adapter: <ul style="list-style-type: none"> ● Rated input voltage: 100 V AC to 240 V AC, 50 Hz to 60 Hz ● Maximum input voltage: 90 V AC to 264 V AC, 47 Hz to 63 Hz ● Rated input current: 0.3 A Output: <ul style="list-style-type: none"> ● Rated output voltage: 5 V DC ● Maximum output current: 1 A
	Maximum power consumption	5 W
	Power supply	DC power adapter
Dimensions and Weight	Casing	Metal
	Product dimensions (W x D x H)	160 mm x 75 mm x 24 mm (6.3 in. x 2.95 in. x 0.94 in.)

	Weight	350 g (0.77 lbs) (without packaging materials)
	Shipping weight	0.60 kg (1.32 lbs)
Environment and Reliability	Fan	Fanless design
	Cooling	Natural cooling
	Mounting options	Wall/Desk
	Hot swapping of cables	Hot swapping supported by the service port and power connector
	MTBF	200,000 hours
	Operating temperature	0°C to 40°C (32°F to 104°F)
	Storage temperature	-40°C to +70°C (-40°F to +158°F)
	Operating humidity	10% RH to 90% RH (non-condensing)
	Storage humidity	5% RH to 95% RH (non-condensing)
	Altitude	<ul style="list-style-type: none"> ● Operating altitude: -500 m to +5,000 m (-1,640.42 ft. to +16,404.20 ft.) ● Storage altitude: -500 m to +5,000 m (-1,640.42 ft. to +16,404.20 ft.)
	ESD protection	<ul style="list-style-type: none"> ● Air discharge: 8 kV ● Contact discharge: 6 kV
	Surge protection	<ul style="list-style-type: none"> ● Service port: ±4 kV for common mode ● Power connector: ±2 kV for common mode and ±1 kV for differential mode
	Earth Leakage Current	≤ 1.5 mA
Certification and Regulatory Compliance	EMC	EN 55032 EN 61000-3-2 EN 61000-3-3 EN 55035 EN 300 386
	Safety compliance	EN 62638-1
	Certification	CE

 **Warning**

Operation of this equipment in a residential environment could cause radio interference.

Product Appearance

On the front panel, the RG-ES108GD Ethernet switch provides eight 10/100/1000Base-T Ethernet ports and one DC power port.

Figure 1-10 Appearance of the RG-ES108GD



Front Panel

Figure 1-11 Front Panel of the RG-ES108GD

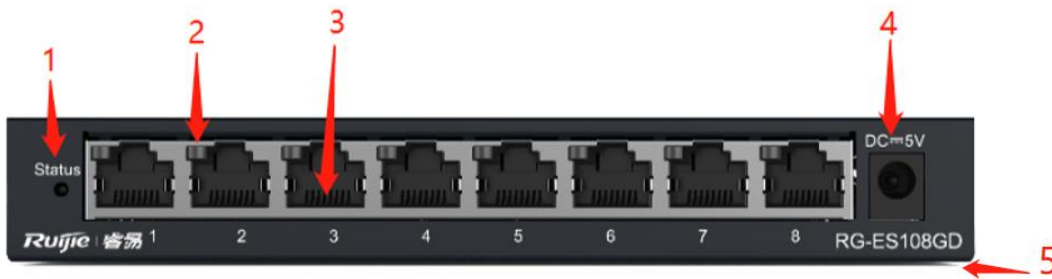

Note:	<ul style="list-style-type: none"> 1. System status LED 2. Port status LED 3. 10/100/1000Base-T Ethernet port 4. DC power port 5. Nameplate on the bottom of the device
-------	--

Back Panel

Figure 1-12 Back Panel of the RG-ES108GD

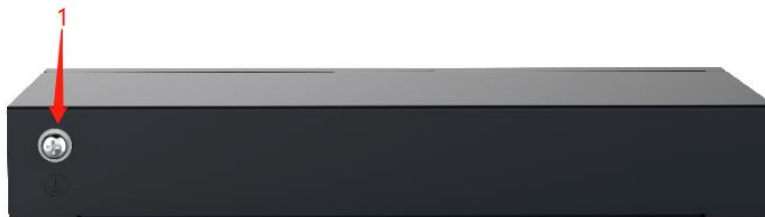

Note:	1. Grounding hole
-------	-------------------

Heat Dissipation

The RG-ES108GD adopts natural heat dissipation, thereby ensuring normal operation. You must maintain a minimum clearance of 100 mm (3.94 in.) around the RG-ES108GD. It is recommended that you clean the device once every three months to avoid dust from blocking vents.

LEDs

LED	Panel Identification	State	Meaning
System status LED	Status	Off	The switch is powered off.
		Solid green	The switch is operational.
RJ45 port status LED	1-8	Off	The port is not connected.
		Solid green	The port is connected at a rate of 10/100/1000 Mbps.
		Blinking green	The port is receiving or sending traffic at a rate of 10/100/1000 Mbps.

2 Preparation Before Installation

2.1 Safety Suggestions

Caution

- To avoid personal injury and device damage, carefully read the safety suggestions before you install the RG-ES100 series switch.
- The following safety suggestions do not cover all possible dangers.

2.1.1 Installation

- Keep the chassis clean and free from any dust.
- Do not place the equipment in a walking area.
- Do not wear loose clothes or accessories that may be hooked or caught by the device during installation and maintenance.
- Turn off all power supplies and remove power sockets and cables before installing or uninstalling the device.

2.1.2 Movement

- Do not frequently move the device.
- When moving the device, note the balance and avoid hurting legs and feet or straining the back.
- Before moving the device, turn off all power supplies and dismantle all power modules.

2.1.3 Electricity

- Observe local regulations and specifications when performing electric operations. Relevant operators must be qualified.
- Before installing the device, carefully check any potential danger in the surroundings, such as ungrounded power supply, and damp or wet ground or floor.
- Before installing the device, find out the location of the emergency power supply switch in the room. First cut off the power supply in the case of an accident.
- Try to avoid maintaining the switch that is powered on alone.
- Make a careful check before you shut down the power supply.
- Do not place the device in a damp location. Do not let any liquid enter the chassis.

 **Caution**

- Any nonstandard and inaccurate electric operation may cause an accident such as fire or electrical shock, thus causing severe even fatal damages to human bodies and the device.
- Direct or indirect touch through a wet object on high-voltage and mains supply may bring a fatal danger.
- If a power supply system is equipped with a leakage protector (leakage current switch or breaker), the rated leakage action current of each leakage protector is twice greater than the maximum leakage current of all the power supplies in the system. For example, if a system is equipped with twenty identical power supplies, the leakage current of each power supply is equal to or less than 1.5 mA, and the total leakage current of the system is 30 mA. A leakage protector with 30 mA rated action current supports less than ten power supplies (that is, action current of the leakage protector/2/maximum leakage current of each power supply = $30/2/1.5 = 10$). In other words, the leakage protector with 30 mA rated action current supports no more than ten power supplies. In this case, the twenty power supplies in the system require at least two leakage protectors with 30 mA rated action current and each leakage protector supports ten power supplies. If power supplies in a system differ in models, the rated leakage action current of each leakage protector divided by two is greater than the sum of maximum leakage current of all the power supplies. The rated leakage non-action current of a leakage protector must be 50% of the leakage action current. The leakage protector with 30 mA rated leakage action current is used as an example. The rated leakage non-action current must be 15 mA. When the leakage current falls below 15 mA, the protector should not act. Otherwise, misoperation may easily occur due to high sensitivity and thus the leakage protector trips, devices are powered off, and services are interrupted.
- To guarantee personal safety, the rated leakage action current of each leakage protector in the system must be equal to or less than 30 mA (human body safety current is 30 mA). When twice of the total leakage current of the system is greater than 30 mA, the system must be equipped with two or more leakage protectors.
- For details of the leakage current value of each power supply model, see Chapter 1 Product Overview.

2.1.4 Static Discharge Damage Prevention

To prevent damage from static electricity, pay attention to the following points:

- Proper grounding of grounding screws on the back panel of the device
- Indoor dust prevention
- Proper humidity conditions

2.2 Installation Site Requirements

The installation site must meet the following requirement to ensure normal working and a prolonged durable life of the switch.

2.2.1 Ventilation

You must maintain a minimum clearance of 100 mm (3.94 in.) around the device. After various cables have been connected, they should be arranged into bundles or placed on the cabling rack to avoid air inlet blocking. It is recommended that the device be cleaned at regular intervals. In particular, avoid dusts from blocking the screen mesh on the back of the cabinet.

2.2.2 Temperature and Humidity

To ensure the normal operation and prolong the service life of RG-ES100 series switch, keep proper temperature and humidity in the equipment room.

If the temperature and humidity in the equipment room do not meet requirements for a long period of time, the device may be damaged.

- In an environment with a high humidity, insulating materials may have bad insulation or even leaking electricity. Sometimes the materials may suffer from mechanical performance change and metallic parts may get rusted.
- In an environment with a low humidity, insulating strips may dry and shrink. Static electricity may occur easily and endanger circuits on the device.
- In an environment with a high temperature, the router is subject to more serious harm. Its performance may degrade significantly and various hardware faults may occur.

The ambient temperature and humidity of the RG-ES100 series switch must meet the requirements listed in Table 2-1.

Table 2-1 Temperature and Humidity Requirements of the RG-ES100 Series Switch

Temperature	Relative Humidity
0°C to 40°C (32°F to 104°F)	10% to 90%

Caution

- The requirements for the sampling site of the temperature and humidity in the operating environment of the device are as follows:
- There is no protective plate at the front or back of the rack.
- The vertical height is 1.5 m above the floor.
- The distance from the front panel of the device is 0.4 m.

2.2.3 Cleanness

Dust poses a severe threat to the running of the device. The indoor dust falling on the device may be absorbed by the static electricity, causing bad contact of the metallic joint. Such electrostatic absorption may occur more easily when the relative humidity is low. This affects the device lifecycle and causes communication faults. Table 2-2 lists the requirements for the dust content and granularity in the equipment room.

Table 2-2 Requirements for the Dust Content and Granularity in the Equipment Room

Dust	Unit	Density
Diameter $\geq 0.5 \mu\text{m}$	Particles/m ³	$\leq 3.5 \times 10^6$
Diameter $\geq 5 \mu\text{m}$	Particles/m ³	$\leq 3 \times 10^4$

Apart from dust, the salt, acid, and sulfide in the air in the equipment room must also meet strict requirements. This is because such poisonous substances may accelerate the corrosion of the metal and the aging of some parts. The equipment room should be protected from the intrusion of harmful gases such as sulfur dioxide, sulfured hydrogen, nitrogen dioxide, and chlorine. Table 2-3 lists the requirements.

Table 2-3 Requirements for Harmful Gases in the Equipment Room

Gas	Average (mg/m ³)	Maximum (mg/m ³)
SO ₂	0.3	1.0
H ₂ S	0.1	0.5
NO ₂	0.5	1.0
Cl ₂	0.1	0.3

 **Caution**

The average and maximum values are measured for a week. The switch cannot be placed in the environment with the maximum density for over 30 minutes every day.

2.2.4 Grounding

A good grounding system is the basis for stable and reliable operation of the device, preventing lightning strokes and resisting interference. Carefully check the grounding conditions at the installation site according to the grounding requirements, and perform grounding operations properly as required.

 **Caution**

- Effective grounding of the switch guarantees surge protection and interference resistance. Therefore, connect the grounding line of the switch properly.
 - The grounding cable is prepared by customers.
-

Safety Grounding

The device using AC power supply must be grounded by using the yellow/green safety ground cable. Otherwise, when the insulating resistance decreases the power supply and the enclosure in the equipment, electric shock may occur.

 **Caution**

- The building must provide the protective grounding connection to ensure that the device is connected to the protection location.
-

- The installation and maintenance personnel must verify that the A.C. socket is properly connected to the protection location of the building. If not, they should use a protective grounding wire to connect the grounding end of the A.C. socket to the building's protection location.
 - The power supply socket must be installed in a place that is near to the device and where users can operate the device easily.
 - Before device installation, ensure that the ground is connected at first and disconnected finally.
 - The sectional area of the protective grounding wire should be at least 0.75 mm² (18 AWG).
 - Use the 3-core power supply line. The sectional area of each pin should be at least 0.75 mm² or 18 AWG.
-

Lightning Grounding

The surge protection system of a facility is an independent system that consists of the lightning rod, down conductor, and connector to the grounding system, which usually shares the power reference ground and ground cable. The lightning discharge ground is targeted for the facility.

EMC Grounding

The grounding required for EMC design includes the shielding ground, filter ground, noise and interference suppression, and level reference. All the above constitute the comprehensive grounding requirements. The resistance of earth wires should be less than 1 Ω. The RG-ES100 series switch back plane is reserved with one grounding pole, as shown in Figure 2-1.

Figure 2-1 Grounding of the RG-ES100

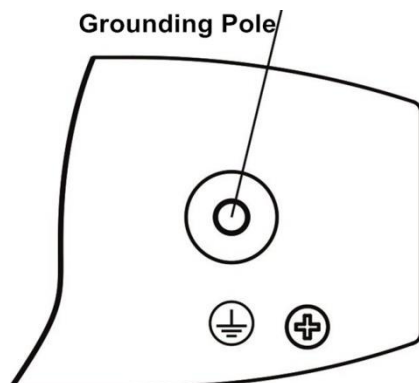

2.2.5 Lightning Resistance

When the AC power cable is imported outdoors and directly connected to the power port of the RG-ES100 series switch, use the lightning line bank to prevent the switch from being hit by lightning shocks. In this case, connect the mains supply AC cable to the lightning line bank, and connect the switch to the lightning line bank. This helps prevent the current of high-voltage lightning from passing the switch directly through the mains supply cable to a certain extent.

⚠ Caution

The lightning line banks are not provided and should be purchased by customers as required.

2.2.6 EMI

Electro-Magnetic Interference (EMI), from either outside or inside the device or application system, affects the system in the conductive ways such as capacitive coupling, inductive coupling, and electromagnetic radiation.

There are two types of electromagnetic interference: radiated interference and conducted interference, depending on the type of the transmission path.

When the energy, often RF energy, from a component arrives at a sensitive component through the space, the energy is known as radiated interference. The interference source can be either a part of the interfered system or a completely electrically isolated unit. Conducted interference results from an electromagnetic wire or signal cable connection between the source and the sensitive component, along which cable the interference conducts from one unit to another. Conducted interference often affects the power supply of the device, but can be controlled by a filter. Radiated interference may affect any signal path in the device and is difficult to shield.

- For the TN AC power supply system, the single-phase three-core power socket with protective earthing conductors (PE) should be adopted to effectively filter out interference from the power grid through filtering circuits.
- Do not use the grounding device for an electrical device or anti-lightning grounding device. In addition, the grounding device of the device must be deployed far away from the grounding device of the electrical device and anti-lightning grounding device.
- Keep the device away from the high-power radio transmitter, radar transmitting station, and high-frequency large-current device.
- Take measures to shield static electricity.
- Lay interface cables inside the equipment room. Outdoor cabling is prohibited, avoiding damages to device signal interfaces caused by over-voltage or over-current of lightning.

2.3 Installation Tools

Table 2-4 Installation Tools

Common Tools	Phillips screwdriver, cables, bolts, diagonal pliers, and straps
Special Tools	Anti-static wrist strap
Meters	Multimeter

Note

The tool kit is customer-supplied.

3 Product Installation

3.1 Installation Flowchart

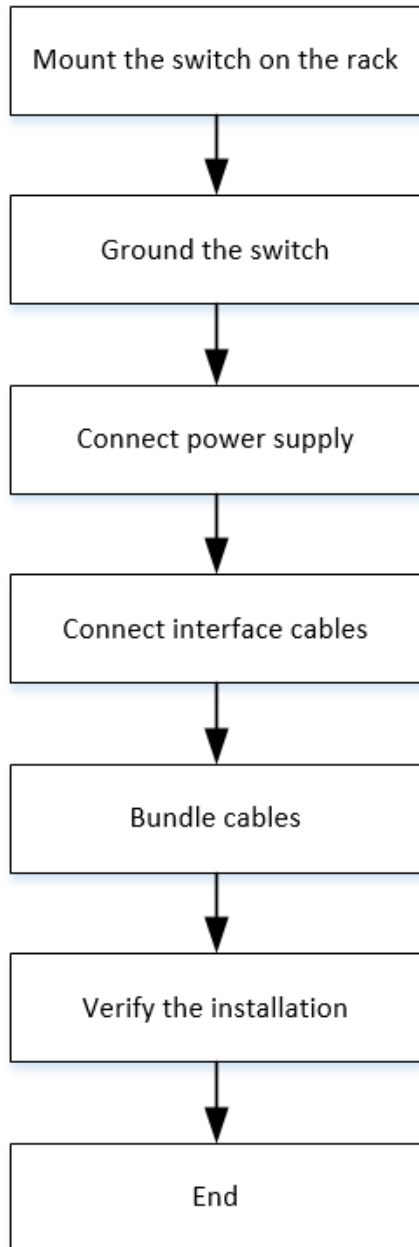

3.2 Precautions Before Installation

Before installation, confirm the following points:

- Check whether ventilation requirements are met for the switch.
- Check whether the requirements of temperature and humidity are met for the switch.

- Check whether power cables are already laid out and whether the requirements of electrical current are met.
- Check whether related network adaption lines are already laid out.

3.3 Installing the RG-ES100

Precautions

During installation, note the following points:

- Connect the power cables of different colors to the corresponding grounding posts.
- Ensure that the interface of the power supply cable is properly connected to the power interface of the device. The power cables must be protected using power cable retention clips after they are connected to the device.
- Do not place any articles on the RG-ES100 series switch.
- Maintain a minimum clearance of 100 mm (3.94 in.) around the device. Do not stack the devices.
- The switch should be located at places free from the large power radio launch pad, radar launch pad, and high-frequency large-current devices. If necessary, use electromagnetic shielding. For example, use interface cables to shield cables.
- 100-meter network cables should be laid inside the equipment room and outdoor cabling of such cables is prohibited. If outdoor cabling is necessary, take relevant measures for surge protection.

3.3.1 Mounting a Switch Against a Wall

The RG-ES108D and RG-ES108GD can be mounted against the wall. Mounting screws and wall anchors are customer supplied.

You need to determine the size and depth of the two mounting holes on the wall based on the sizes of wall anchors and screws. Ensure that the wall anchors can be inserted into the holes. The outer edges of the wall anchors are left outside the wall, so screws can be tightly fastened to the wall.

The steps of mounting the switch against the wall are as follows:

Step 1: As shown in Figure 3-1, drill two holes 64 mm (2.52 in.) far away from each other. The line of connecting the two holes is horizontal.

Step 2: Insert wall anchors into the holes and ensure that the outer edges of the wall anchors are aligned with the wall.

Step 3: Put screws (ST4.2x20 recommended) into the wall anchors. Ensure that the distance between the inner side of the screw head and the outer edge of the wall anchors not be smaller than 2.5 mm (0.10 in.) so that the device can be securely mounted on the screws.

Step 4: Align the two mounting holes on the bottom of the chassis of the device with the screws, and then fasten the device on the screws.

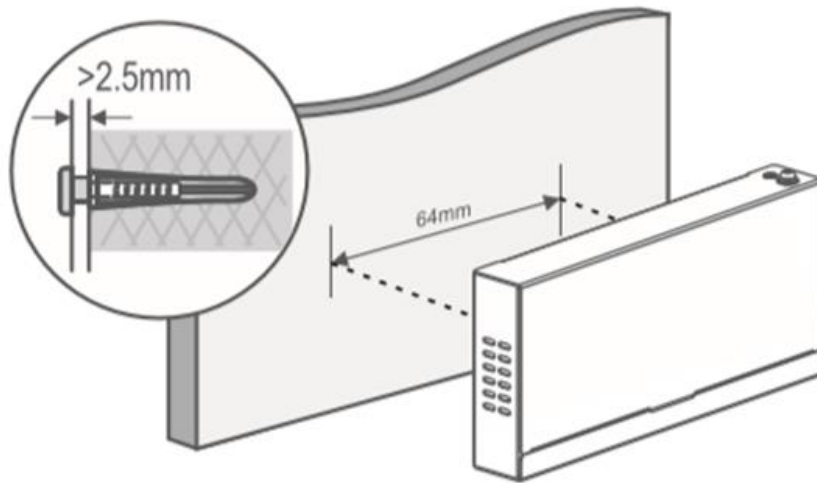
Figure 3-1 Mounting the Switch Against the Wall

3.3.2 Mounting the Switch on a Table

Place the switch on a table.

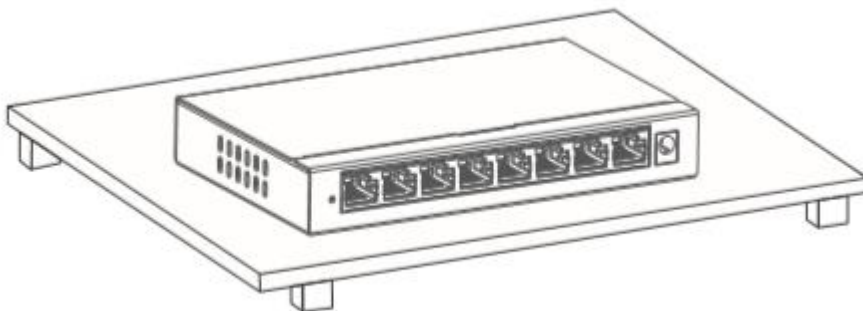
Figure 3-2 Placing the Switch on a Table

⚠ Caution

The device must be installed and operated in the place that can restrict its movement.

3.4 Checking After Installation

⚠ Caution

Before checking the installation, switch off the power supply so as to avoid any personal injury or damage to the component due to connection errors.

- Check that the ground line is connected.
- Check that the cables and power input cables are correctly connected.

- Check that all interface cables are laid out inside the equipment room. In the case of external cabling, check that the lightning resistance socket or network interface lightning protector is connected.
- Maintain a minimum clearance of 100 mm (3.94 in.) around the device.

4 System Commissioning

4.1 Startup Check

4.1.1 Checking Before the Device Is Powered On

- The switch is well grounded.
- The power cable is correctly connected.
- The power supply voltage complies with the requirement of the switch.

4.1.2 Checking After Program Startup (Recommended)

After power-on, you are advised to perform the following checks to ensure the normal operation of follow-up configurations.

- Check whether the status of the switch indicator is normal.
- Check whether the service interface forwards data normally.

5 Maintenance and Troubleshooting

5.1 Troubleshooting Procedure

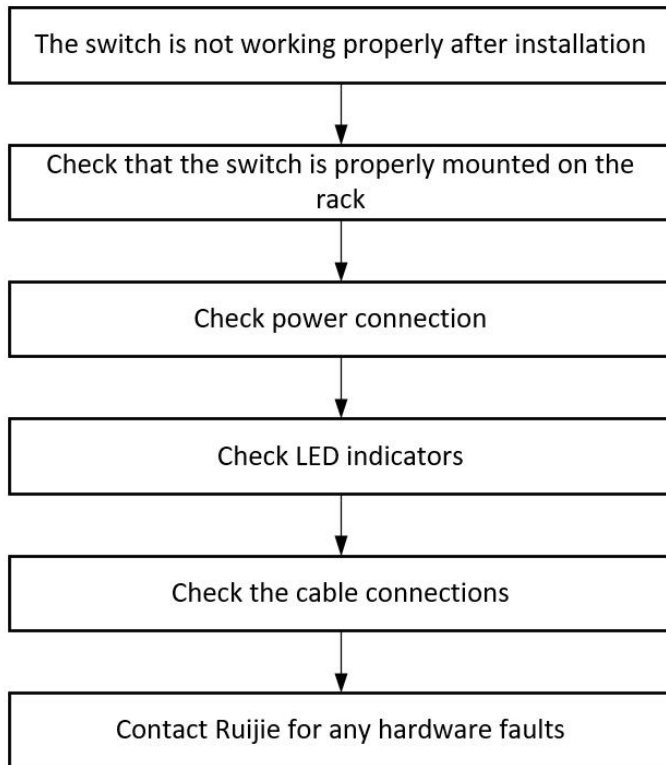

5.2 Troubleshooting Common Faults

Symptom	Possible Causes	Solution
The status indicator is not on after the switch is started.	<p>The power module does not work.</p> <p>The power cable is in loose contact.</p>	<p>Check whether the power socket in the equipment room is normal and whether the power cable is installed.</p>
The RJ45 port is not connected or an error occurs when the port is receiving or transmitting frames.	<p>The connected twisted pair cable is faulty.</p> <p>The length of the cable exceeds 100 m.</p> <p>The port has special configuration, which does not adapt to the working mode of the connected switch.</p>	<p>Replace the twisted pair cable.</p> <p>Check that the working mode of the port must adapt to that of the connected switch.</p>

Symptom	Possible Causes	Solution
The fiber port cannot be connected.	The Rx and Tx ends are connected reversely.	Switch the Rx and Tx ends of the optical fiber.
	The interconnected optical module type does not match.	Replace the optical module with one of the matched type.
	The fiber type is incorrect.	Replace the optical fiber with one of the appropriate type.
	The length of the optical fiber exceeds that rated of the optical module.	Replace the optical fiber with one of the appropriate length.

6 Appendix A Connectors and Connection Media

1000BASE-T/100BASE-TX/10BASE-T Ports

The 1000BASE-T/100BASE-TX/10BASE-T supports adaptation of three rates and automatic MDI/MDIX crossover at these three rates.

The 1000BASE-T complies with IEEE 802.3ab, and uses the cable of 100-ohm Category-5 or Supper Category-5 UTP or STP, which can be up to 100 m.

The 1000BASE-T port uses four pairs of wires for transmission, all of which must be connected. [Figure 6-1](#) shows the connections of the twisted pairs used by the 1000BASE-T port.

Figure 6-1 Four Twisted Pairs of the 1000BASE-T

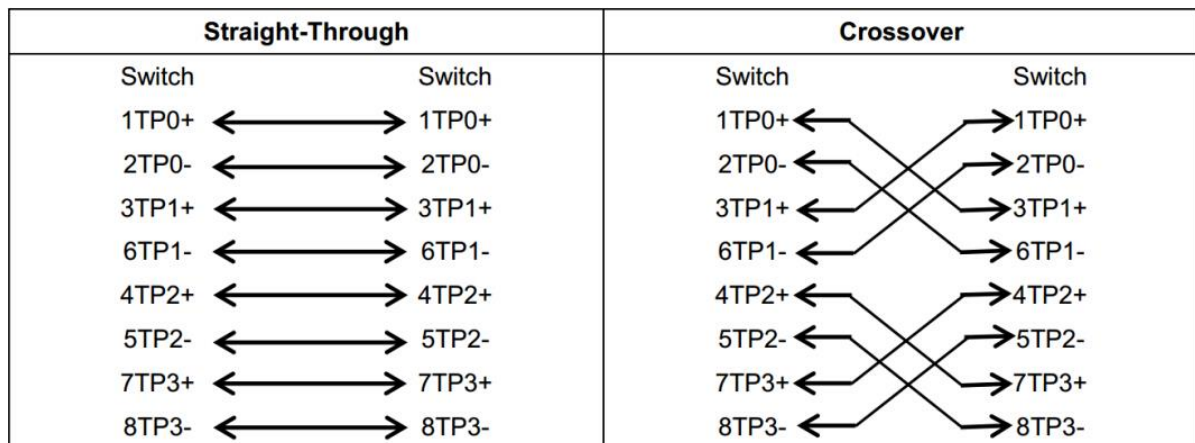

In addition to the preceding cables, the 100BASE-TX/10BASE-T can also use 100-ohm Category-3, Category-4, and Category-5 cables for 10 Mbps, and 100-ohm Category-5 cables for 100 Mbps, both of which can be up to 100 m. [Figure 6-2](#) shows the pinouts of the 100BASE-TX/10BASE-T.

Figure 6-2 Pinouts of the 100BASE-TX/10BASE-T

Pin	Socket	Plug
1	Input Receive Data+	Output Transmit Data+
2	Input Receive Data-	Output Transmit Data-
3	Output Transmit Data+	Input Receive Data+
6	Output Transmit Data-	Input Receive Data-
4,5,7,8	Not used	Not used

Figure 6-3 shows the straight-through and crossover cable connections for the 100BASE-TX/10BASE-T.

Figure 6-3 Connections of the Twisted Pairs of the 100BASE-TX/10BASE-T

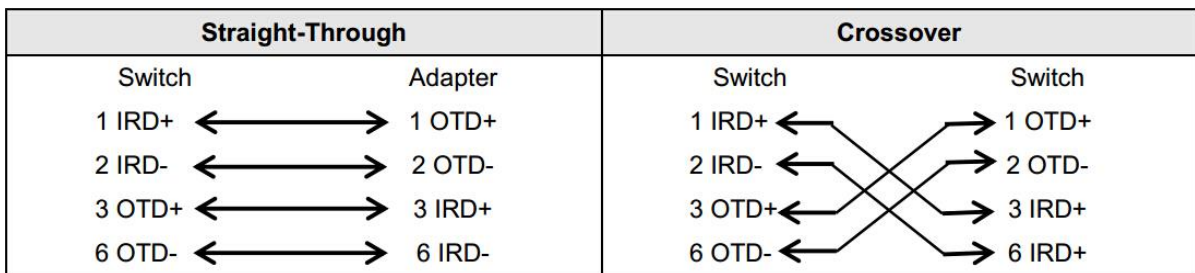

7 Appendix B Site Selection

- The equipment room should be at least 5 km away from the heavy pollution source such as the smelter, coal mine, and thermal power plant, 3.7 km away from the medium pollution source such as the chemical industry, rubber industry, and electroplating industry, and 2 km away from the light pollution source such as the food manufacturer and leather plant. If the pollution source is unavoidable, the equipment room should be located on the windward side of the pollution source perennially with advanced protection.
- The equipment room should be at least 3.7 km away from the sea or salt lake. Otherwise, the equipment room must be sealed, with air conditioner installed for temperature control. Saline soil cannot be used for construction. Otherwise, you should select devices with advanced protection against severe environment.
- Do not build the equipment room in the proximity of livestock farms. Otherwise, the equipment room should be located on the windward side of the pollution source perennially. The previous livestock house or fertilizer warehouse cannot be used as the equipment room.
- The equipment room should be firm enough to withstand severe weather conditions such as windstorm and heavy rain as well as away from dust. If the dust is unavoidable, keep the door and window away from the pollution source.
- The equipment room should be away from the residential area. Otherwise, the equipment room should meet the construction standard in terms of noise.
- Make sure that the air vent of the equipment room is away from the sewage pipe, septic tank, and sewage treatment tank. Keep the equipment room under positive pressure to prevent corrosive gas from entering the

equipment room to corrode components and circuit boards. Keep the equipment room away from industrial boiler and heating boiler.

- The equipment room had better be on the second floor or above. Otherwise, the equipment room floor should be 600 mm higher than the highest flood level ever recorded.
- Make sure that there are no cracks or holes in the wall and floor. If there are cable entries in the wall or window, take proper sealing measures. Ensure that the wall is flat, wear-resistant, and dust-free, which must meet requirements of flame retarding, soundproofing, heat absorption, dust reduction, and electromagnetic shielding.
- Keep the door and the window closed to make the equipment room sealed.
- The steel door is recommended for soundproofing.
- Sulfur-containing materials are forbidden.
- Pay attention to the location of the air conditioner. Keep the air conditioner from blowing wind straight toward the device or blowing water drops from the window or air vent toward the device.

8 Appendix C Surge Protection

Installing the AC Power Arrester (Surge Protection Cable Row)

The external surge protection cable row must be used on the AC power port to prevent the switch from being struck by lightning when the AC power cable is introduced from the outdoor and directly connected to the power port of the switch. The surge protection cable row is fixed on the cabinet, operating table, or the wall in the equipment room using the line buttons and screws.

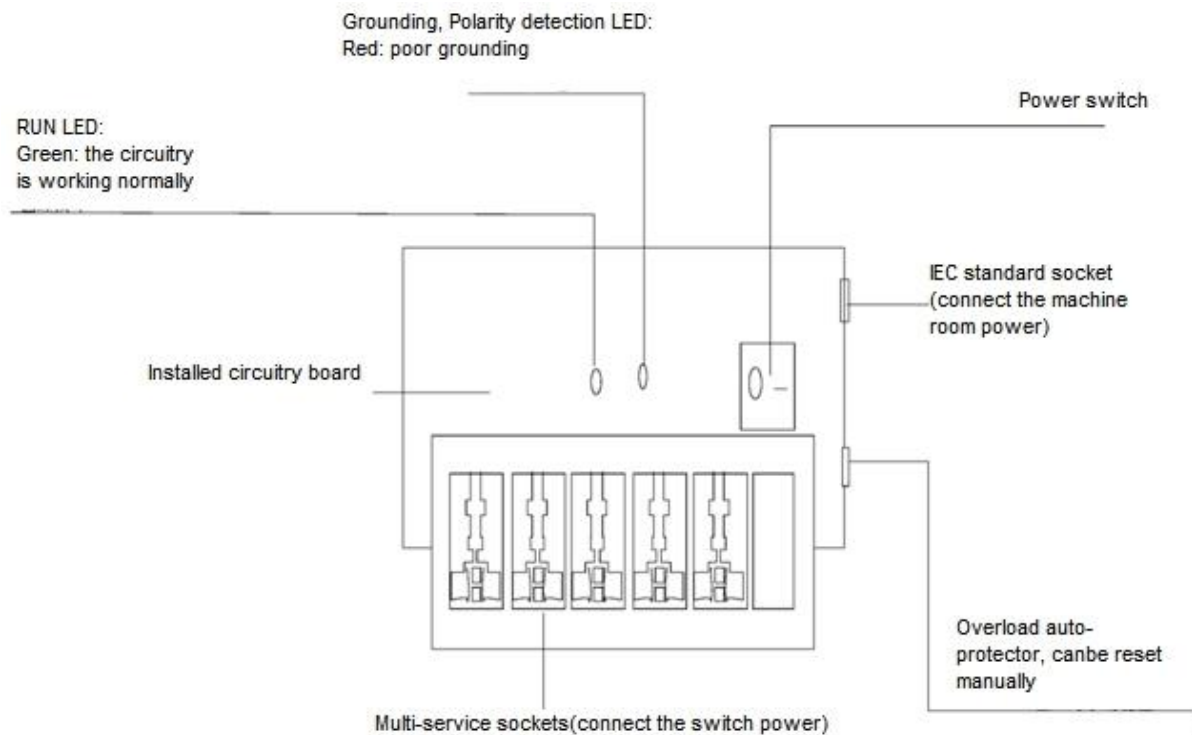
Figure 8-1 Schematic Diagram for the Power Arrester

⚠ Caution

The power arrester is not provided and customers have to purchase it.

Precautions for installation:

- Ensure that the PE terminal of the power arrester is properly grounded.
- After connecting the switch AC power plug to the socket of the power arrester (surge protection cable row), surge protection function implements if the RUN LED is Green and the ALARM LED is OFF.
- If the alarm LED on the power arrester is red, check whether there is the poor grounding connection or reversed connection of null and live lines. You can use the multimeter to check the polarity of the power socket for the arrester when the LED is red. If the N line is on the left and the L line is on the right, the arrester PE terminal is not grounded. If the L line is on the left and the N line is on the right, the polarity of the arrester power cable is reversed. If the LED is still red, the arrester PE terminal is not grounded.

Installing the Ethernet Port Arrester

During the switch usage, the Ethernet port arrester must be connected to the switch to prevent the switch damage by lightning before the outdoor network cable connects to the switch.

Tools: cross or straight screwdriver, multimeter, and diagonal pliers

Installation steps:

- (1) Tear one side of the protection paper for the double-sided adhesive tape and paste the tape to the framework of the Ethernet port arrester. Tear the other side of the protection paper for the double-sided adhesive tape

- and paste the Ethernet port arrester to the switch framework. The paste location for the Ethernet port arrester must be as close to the grounding terminal of the switch.
- (2) Based on the distance of the switch grounding terminal, cut the grounding line for the Ethernet port arrester and firmly tighten the grounding line to the grounding terminal of the switch.
 - (3) Use the multimeter to check whether the grounding line for the arrester is in good contact with the switch grounding terminal and the framework.
 - (4) According to the *Ethernet Port Arrester Hardware Installation Guide*, connect the arrester using the adapter cable (note that the external network cable is connected to the end of IN, while the adapter cable connected to the switch is connected to the end of OUT) and check whether the LED on the board is normal.
 - (5) Use the nylon button to bundle the power cables.

Figure 8-2 Schematic Diagram for the Ethernet Port Arrester Installation

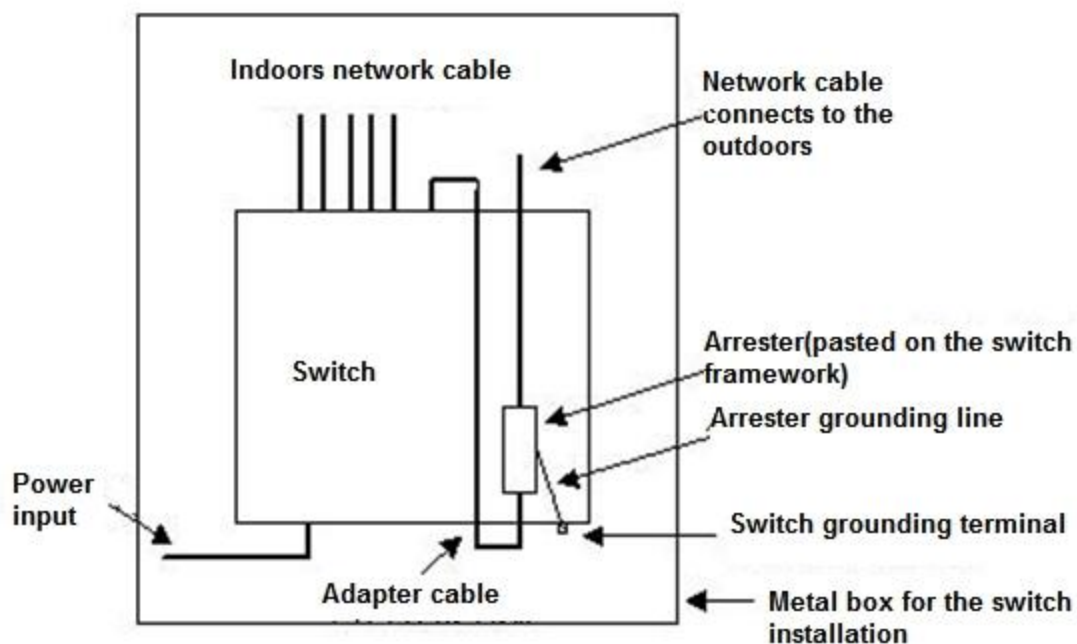

⚠ Caution

- The Ethernet port arrester applies to only the 10M/100M copper Ethernet ports with the RJ45 connector.
- The Ethernet port arrester is provided by customers. For more information about arrester installation, refer to *Ethernet Port Arrester Hardware Installation Guide*.

To prevent the performance of the Ethernet port arrester from being affected, note the following points:

- Reversed direction of the arrester installation: Connect the external network cable to the IN end and connect the switch Ethernet port to the OUT end.
- Poor arrester grounding: The grounding line must be as short as possible to ensure that it is in good contact with the switch grounding terminal. Use the multimeter to confirm the contact after grounding.
- Incomplete arrester installation: If more than one port is connected to the peer device on the switch, install the arresters on all connection ports for surge protection.

9 Appendix D Cabling Recommendations in Installation

When RG-ES100 series switches are installed in standard 19-inch cabinets, cables are tied in the binding rack on the cabinet by the cabling rack, and top or bottom cabling is adopted according to the actual situation in the equipment room. All cable connectors should be placed at the bottom of the cabinet in an orderly manner but not outside the cabinet. Power cables are routed beside the cabinet, and top or bottom cabling is adopted according to the actual situation in the equipment room, such as the position of the DC power distribution box, AC socket, or surge protection box.

Requirement for the Minimum Cable Bending Radius

- The bending radius of a power cord, communication cable, and flat cable should be five times greater than their respective diameters. The bending radius of these cables that often bend or is removed or installed should be seven times greater than their respective diameters.
- The bending radius of a common coaxial cable should be seven times greater than its diameter. The bending radius of this type of cables that often bend or is removed or installed should be 10 times greater than its diameter.
- The bending radius of a high-speed cable (for example, SFP cable) should be five times greater than its diameter. The bending radius of this type of cables that often bend or is removed or installed should be 10 times greater than its diameter.

Requirement for the Minimum Fiber Bending Radius

- The diameter of a fiber tray to hold fibers cannot be 25 times less than the diameter of the fiber.
- When moving an optical fiber, the bending radius of the fiber should be equal to or 20 times greater than the diameter of the fiber.
- During cabling of an optical fiber, the bending radius of the fiber should be equal to or 10 times greater than the diameter of the fiber.

Precautions for Bundling Up Cables

- Before bundling up cables, correctly mark labels and stick the labels to cables.
- Cables should be neatly and properly bundled, as shown in [Figure 9-1](#).

Figure 9-1 Bundling Up Cables (1)

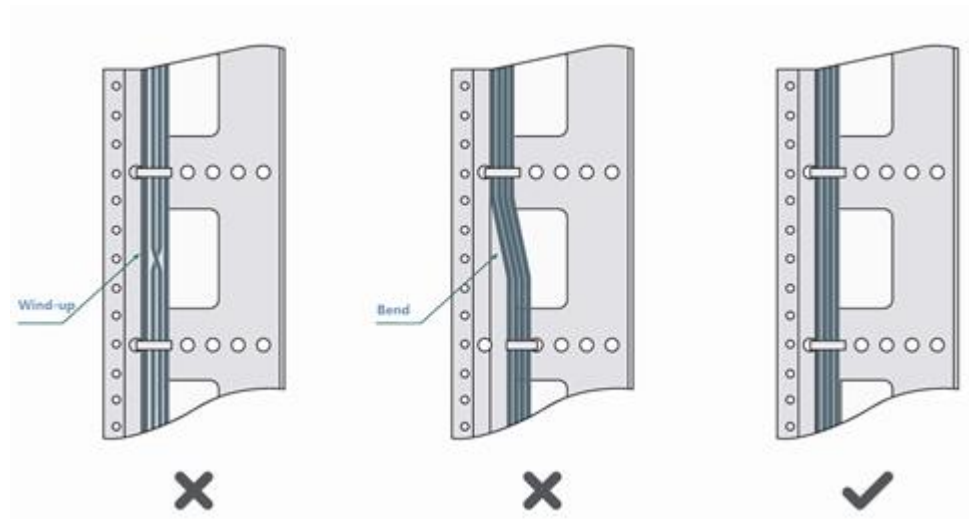

- Cables of different types (such as power cords, signal cables, and ground cables) should be separated in cabling and bundling. When they are close, crossover cabling can be adopted. In the case of parallel cabling, maintain a space of at least 30 mm for power cords and signal cables.
- The binding rack and cabling slot inside and outside the cabinet should be smooth, without sharp corners.
- The metal hole traversed by cables should have a smooth and fully rounding surface or an insulated lining.
- Proper buckles should be selected to bundle up cables. It is forbidden to connect two or more buckles to bundle up cables.
- After bundling up cables with buckles, you should cut off the remaining part. The cut should be smooth and trim, without sharp corners, as shown in [Figure 9-2](#).

Figure 9-2 Bundling Up Cables (2)

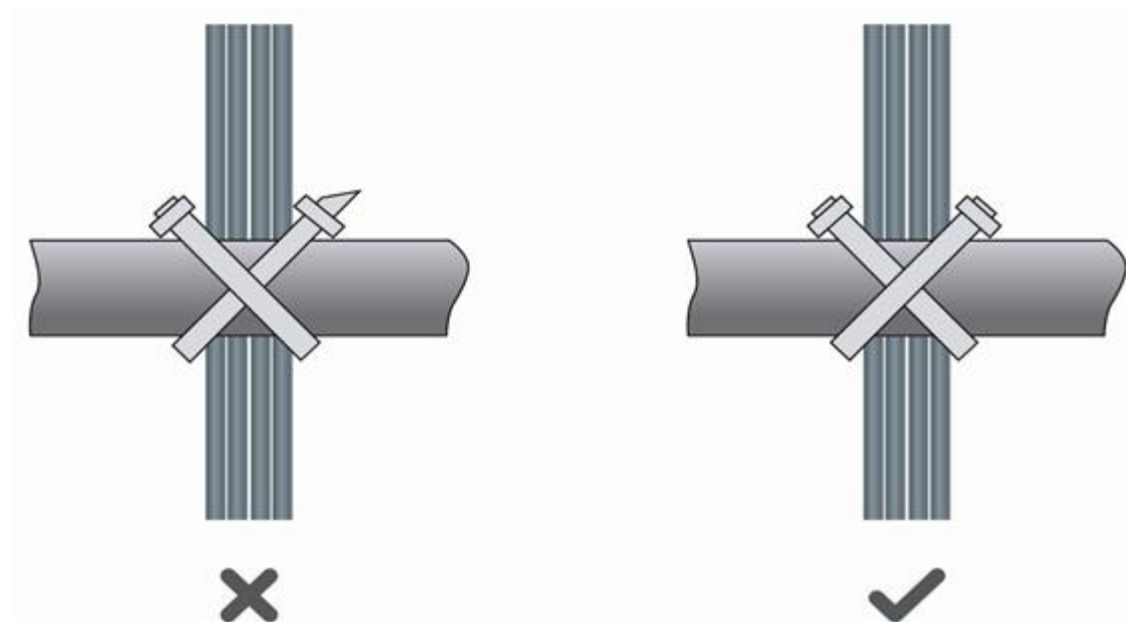

- When cables need to bend, first bundle them up. However, the buckle cannot be bundled within the bending area. Otherwise, significant stress may be generated in cables, breaking cable cores.

Figure 9-3 Bundling Up Cables (3)

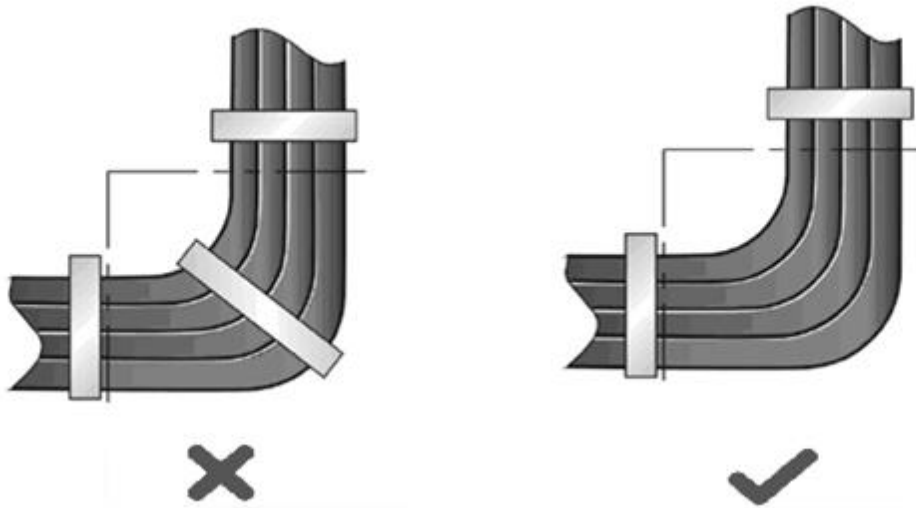

- Cables not to be assembled or remaining parts of cables should be folded and placed in a proper position of the cabinet or cabling slot. The proper position will not affect device running or cause device or cable damage during commissioning.
- Power cords cannot be bundled on guide rails of moving parts.
- Power cables connecting moving parts such as door grounding wires should be reserved for access after being assembled. When the moving part reaches the installation position, the remaining part should not touch heat sources, sharp corners, or sharp edges. If heat sources cannot be avoided, high-temperature cables should be used.
- When using screw threads to fasten cable terminals, the bolt or screw must be tightly fastened, and anti-loosening measures should be taken, as shown in [Figure 9-4](#).

Figure 9-4 Cable Fastening

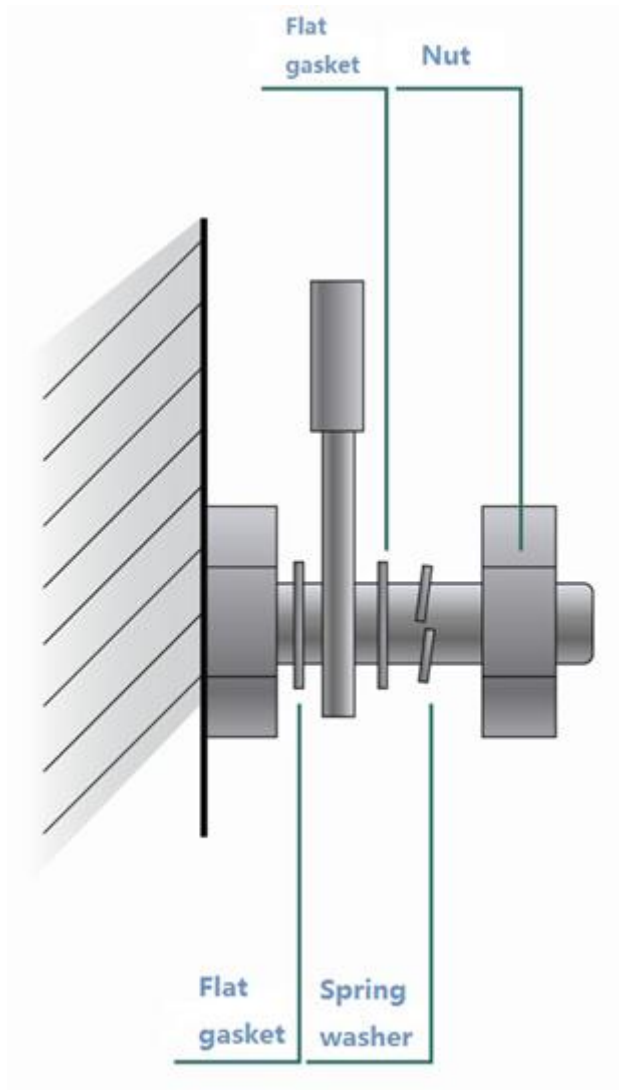

- The hard power cable should be fastened by the terminal connection area to prevent stress.
- Do not use self-tapping screws to fasten terminals.
- Power cables of the same type in the same cabling direction should be bundled up into cable bunches, with clean and straight cables in cable bunches.
- Binding by using buckles should be performed according to [Table 9-1](#).

Table 9-1

Cable Bunch Diameter (mm)	Binding Space (mm)
10	80–150
10–30	150–200
30	200–300

- No knot is allowed in cabling or bundling.

- For solder-less terminal blocks (such as air switches) of the cold pressing terminal type, the metal part of the cold pressing terminal should not be exposed outside the terminal block during assembly.