

Ruijie Reyee RG-RAP72 Access Point

Installation Guide

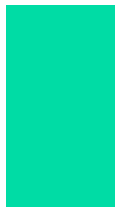
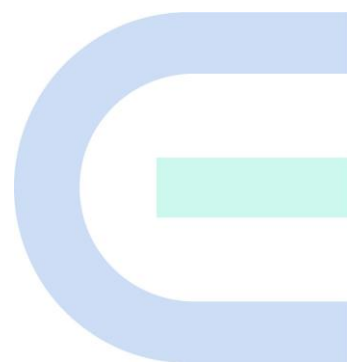

Copyright

Copyright © 2025 Ruijie Networks

All rights are reserved in this document and this statement.

Without the prior written consent of Ruijie Networks, any organization or individual shall not reproduce, extract, back up, modify, or propagate the content of this document in any manner or in any form, or translate it into other languages or use some or all parts of the document for commercial purposes.

 and other Ruijie networks logos are trademarks of Ruijie Networks.

All other trademarks or registered trademarks mentioned in this document are owned by their respective owners.

Disclaimer

The products, services, or features you purchase are subject to commercial contracts and terms, and some or all of the products, services, or features described in this document may not be available for you to purchase or use. Except for the agreement in the contract, Ruijie Networks makes no explicit or implicit statements or warranties with respect to the content of this document.

The names, links, descriptions, screenshots, and any other information regarding third-party software mentioned in this document are provided for your reference only. Ruijie Networks does not explicitly or implicitly endorse or recommend the use of any third-party software and does not make any assurances or guarantees concerning the applicability, security, or legality of such software. You should choose and use third-party software based on your business requirements and obtain proper authorization. Ruijie Networks assumes no liability for any risks or damages arising from your use of third-party software.

The content of this document will be updated from time to time due to product version upgrades or other reasons, Ruijie Networks reserves the right to modify the content of the document without any notice or prompt.

This manual is designed merely as a user guide. Ruijie Networks has tried its best to ensure the accuracy and reliability of the content when compiling this manual, but it does not guarantee that the content of the manual is completely free of errors or omissions, and all the information in this manual does not constitute any explicit or implicit warranties.

Preface

Intended Audience

This document is intended for:

- Network engineers
- Technical support and servicing engineers
- Network administrators

Technical Support

- Ruijie Reye website: <https://reyee.ruijie.com>
- Online support center: <https://reyee.ruijie.com/en-global/support>
- Case portal: <https://www.ruijie.com/support/caseportal>
- Community: <https://community.ruijie.com>
- Email support: service_rj@ruijie.com
- Live chat: <https://reyee.ruijie.com/en-global/rita>

Conventions

The signs used in this document are described as follows:

1. Signs

Danger

An alert that contains important safety instructions. Before you work on any equipment, be aware of the hazards involved and be familiar with standard practices in case of accidents.

Warning

An alert that calls attention to important rules and information that if not understood or followed can result in data loss or equipment damage.

Caution

An alert that calls attention to essential information that if not understood or followed can result in function failure or performance degradation.

Note

An alert that contains additional or supplementary information that if not understood or followed will not lead to serious consequences.

Specification

An alert that contains a description of product or version support.

2. Notes

This manual presents installation instructions, troubleshooting techniques, technical specifications, cable and connector requirements, and usage guidelines. It is intended for users who want to gain insight into the above content and have some experience in installing and maintaining network hardware. It is assumed that users are already familiar with relevant terms and concepts.

Contents

Preface	I
1 Overview	1
1.1 About the RG-RAP72	1
1.2 Package Contents.....	1
1.3 Product Appearance	2
1.3.2 Front Panel.....	2
1.3.3 Rear Panel	3
1.4 Technical Specifications	4
1.5 Power Supply.....	8
1.6 Cooling.....	9
2 Preparing for Installation	10
2.1 Safety Guidelines.....	10
2.1.1 General Safety Guidelines.....	10
2.1.2 Chassis-Lifting Guidelines	10
2.1.3 Electrical Safety Guidelines.....	10
2.2 Site Requirements	11
2.2.1 Bearing Requirements	11
2.2.2 Space Requirements	11
2.2.3 Ventilation Requirements.....	11
2.2.4 Temperature/Humidity Requirements	11
2.2.5 Cleanliness Requirements.....	12
2.2.6 ESD Requirements	12
2.2.7 EMI Requirements	13

2.3 Tools	13
3 Installing the AP.....	14
3.1 Before You Begin.....	14
3.2 Safety Precautions During Installation	14
3.3 Installing the AP	15
3.3.1 Mounting the AP on a Ceiling or Wall	15
3.3.2 Mounting the AP in an 86 mm Junction Box.....	19
3.4 Removing the AP	21
3.5 Connecting Cables.....	22
3.6 Bundling Cables.....	22
3.7 Verifying the Installation.....	23
4 Commissioning.....	24
4.1 Setting Up the Configuration Environment	24
4.2 Powering on the AP	24
4.2.1 Checklist Before Power-On	24
4.2.2 Checklist After Power-on	24
4.3 Troubleshooting Power Supply Failures.....	24
5 Monitoring and Maintenance.....	25
5.1 Monitoring	25
5.2 Hardware Maintenance.....	25
6 Common Troubleshooting.....	26
6.1 Troubleshooting Flowchart	26
6.2 Common Faults.....	26
6.2.1 The LED is Off After the AP is Powered On	26

6.2.2 Ethernet Port Is Not Working After the Ethernet Cable Is Plugged In.....	26
6.2.3 A Client Cannot Discover the AP	26
7 Appendix.....	28
7.1 Connectors and Media.....	28
7.1.1 10/100/1000/2.5GBASE-T Port	28
7.2 Cabling Recommendations.....	30
7.2.1 Requirements for the Minimum Bend Radius of Ethernet Cables	30
7.2.2 Precautions for Cable Bundling	30

1 Overview

1.1 About the RG-RAP72

The RG-RAP72 is a Wi-Fi 7 dual-band, ceiling-mounted wireless access point (AP) launched by Ruijie Reyee, designed for indoor environments such as offices, hotels, and schools. It supports IEEE 802.3af/at-compliant Power over Ethernet (PoE) and a 12 V/1.5 A local power supply, allowing you to choose the most suitable power supply mode based on your needs. In compliance with IEEE 802.11a/b/g/n/ac/ax/be standards, the RG-RAP72 operates on both the 2.4 GHz and 5 GHz frequency bands. It delivers ultra-fast speeds of up to 3570 Mbps, with 688 Mbps on the 2.4 GHz band and 2882 Mbps on the 5 GHz band, fulfilling requirements for high-speed wireless connectivity. This AP provides one 2.5 Gbps Ethernet port to fully utilize high-speed wireless performance. With Reyee's self-organizing networking (SON) technology, the RG-RAP72 ensures comprehensive indoor Wi-Fi coverage and meets diverse networking requirements for various services.

1.2 Package Contents

Table 1-1 Package Contents

No.	Item	Quantity
1	RG-RAP72 access point	1
2	Mounting bracket	1
3	Cross pan head screws (ST4.2 x 20 mm)	4
4	Plastic expansion anchors ($\phi 9$ x 25.4 mm)	4
5	User Manual	1
6	Key to security lock	1
7	Alignment sticker	1
8	Warranty Card	1

Note

The package contents are subject to the purchase contract, and actual delivery may vary. Please check the items carefully against the package contents or purchase contract. If you have any questions, please contact the distributor.

1.3 Product Appearance

Figure 1-1 Appearance of the RG-RAP72



1.3.2 Front Panel

Figure 1-2 Front Panel of the RG-RAP72

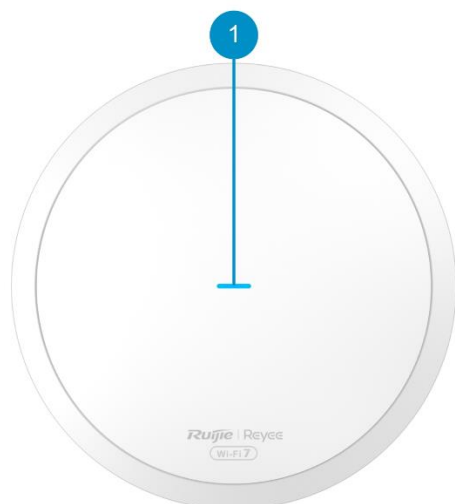

Table 1-2 LEDs

No.	Item	Status	Description
1	System status LED	Solid blue	The AP is operating normally without any alarms.
		Off	The AP is not receiving power.
		Fast blinking blue (8 Hz)	The AP is starting up.
		Slow blinking blue (0.5 Hz)	The AP is not connected to the Internet.
		Two blue flashes	Possible cases are as follows: <ul style="list-style-type: none"> ● The AP is being reset. ● The AP is being upgraded. ● The AP is recovering. <hr/> ⚠ Caution Do not power off the AP when its LED is in this state.
Blinking blue (three quick flashes followed by one slow flash)	Other faults have occurred.		

1.3.3 Rear Panel

Figure 1-3 Rear Panel of the RG-RAP72

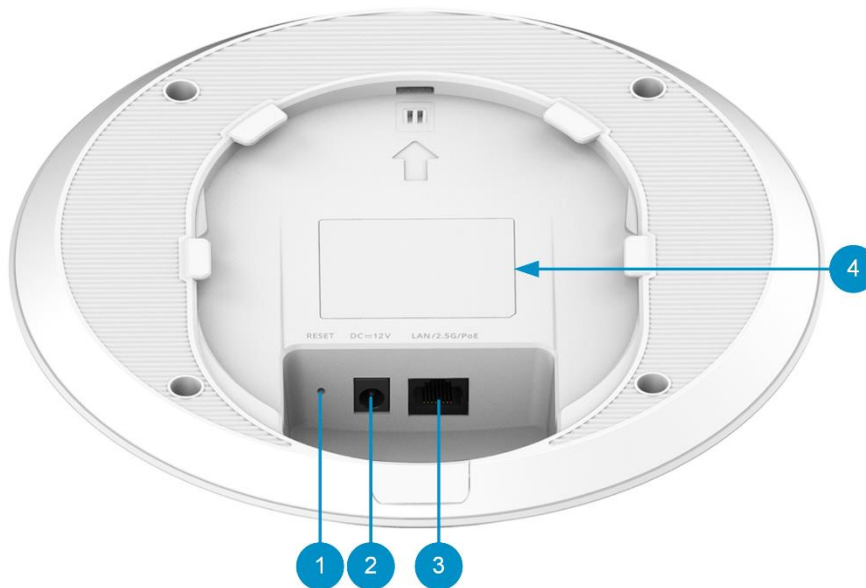

Table 1-3 Components on the Rear Panel

No.	Component	Description
1	Reset button	Press and hold it for less than 2s to restart the AP.
		Press and hold it for more than 5s to restore the AP to factory settings.
2	DC=12V connector	Connects to a DC power adapter for power supply. The DC power voltage is 12 V and the current is 1.5 A.
3	LAN/2.5G/PoE port	1 x 10/100/1000/2500BASE-T Ethernet port that supports PoE input.
4	Nameplate	The nameplate is located at the bottom of the device.

1.4 Technical Specifications

Table 1-4 Technical Specifications

System Specifications	Flash memory	256 MB
	RAM	512 MB DDR3
Wi-Fi Radio	5 GHz Wi-Fi	Wi-Fi 4 (IEEE 802.11a/n) Wi-Fi 5 (IEEE 802.11ac) Wi-Fi 6 (IEEE 802.11ax) Wi-Fi 7 (IEEE 802.11be)
	2.4 GHz Wi-Fi	Wi-Fi 4 (IEEE 802.11b/g/n) Wi-Fi 6 (IEEE 802.11ax) Wi-Fi 7 (IEEE 802.11be)
	Operating band	IEEE 802.11b/g/n/ax/be, 2.400 GHz to 2.4835 GHz IEEE 802.11a/n/ac/ax/be, 5.150 GHz to 5.350 GHz, 5.470 GHz to 5.725 GHz, 5.725 GHz to 5.850 GHz Note: Available bands vary with countries and regions. To use the preceding frequency bands, ensure that your country or region supports these frequency bands.
	Radio design	Dual-radio 4 spatial streams <ul style="list-style-type: none"> ● 2.4 GHz: 2 x 2, MU-MIMO ● 5 GHz: 2 x 2, MU-MIMO
	5 GHz channel width	Auto/20/40/80/160 MHz

	2.4 GHz channel width	Auto/20/40 MHz
	Maximum wireless data rate	3570 Mbps
	5 GHz wireless data rate	2882 Mbps
	2.4 GHz wireless data rate	688 Mbps
	Maximum transmit power (5 GHz)	<p>Combined power: 25.7 dBm (single-stream power: 21 dBm)</p> <p>Note: The transmit power varies according to regulations in different countries and regions.</p>
	Maximum transmit power (2.4 GHz)	<p>Combined power: 25 dBm (single-stream power: 22 dBm)</p> <p>Note: The transmit power varies according to regulations in different countries and regions.</p>
	Maximum transmit power	<p>Frequency bands and maximum Effective Isotropic Radiated Power (EIRP):</p> <p>Note: Country specific restrictions apply.</p> <ul style="list-style-type: none"> ● European Union & United Kingdom <ul style="list-style-type: none"> ○ 2400–2483.5 MHz, EIRP ≤ 20 dBm ○ 5150–5350 MHz, EIRP ≤ 23 dBm ○ 5470–5725 MHz, EIRP ≤ 30 dBm ● Myanmar: <ul style="list-style-type: none"> ○ 2400–2483.5 MHz, EIRP ≤ 23 dBm ○ 5725–5825 MHz, EIRP ≤ 30 dBm ● Thailand: <ul style="list-style-type: none"> ○ 2400–2483.5 MHz, EIRP ≤ 20 dBm ○ 5150–5350 MHz, EIRP ≤ 23 dBm ○ 5470–5725 MHz, EIRP ≤ 30 dBm ○ 5725–5825 MHz, EIRP ≤ 30 dBm ● Indonesia: <ul style="list-style-type: none"> ○ 2400–2483.5 MHz, EIRP ≤ 27 dBm ○ 5150–5350 MHz, EIRP ≤ 23 dBm ○ 5725–5825 MHz, EIRP ≤ 23 dBm ● Egypt: <ul style="list-style-type: none"> ○ 2400–2483.5 MHz, EIRP ≤ 20 dBm ○ 5150–5350 MHz, EIRP ≤ 23 dBm
	Coverage range	140 m ² (1506.95 square ft.)

		Note: The data is obtained in an ideal environment without obstruction. The signal coverage radius depends on client performance and environmental interference.
	Modulation	<p>OFDM: BPSK @ 6/9 Mbps, QPSK @ 12/18 Mbps, 16-QAM @ 24 Mbps, and 64-QAM @ 48/54 Mbps</p> <p>DSSS: DBPSK @ 1 Mbps, DQPSK @ 2 Mbps, and CCK @ 5.5/11 Mbps</p> <p>MIMO-OFDM: BPSK, QPSK, 16-QAM, 64-QAM, 256-QAM, 1024-QAM, and 4096-QAM</p> <p>OFDMA</p>
	Receive sensitivity	<p>11b: -91 dBm (1 Mbps), -88 dBm (5.5 Mbps), -85 dBm (11 Mbps)</p> <p>11a/g: -89 dBm (6 Mbps), -80 dBm (24 Mbps), -76 dBm (36 Mbps), -71 dBm (54 Mbps)</p> <p>11n: -83 dBm (MCS0), -65 dBm (MCS7), -83 dBm (MCS8), -65 dBm (MCS15)</p> <p>11ac: 20 MHz: -83 dBm (MCS0), -57 dBm (MCS9)</p> <p>11ac: 40 MHz: -79 dBm (MCS0), -57 dBm (MCS9)</p> <p>11ac: 80 MHz: -76 dBm (MCS0), -51 dBm (MCS9)</p> <p>11ac: 160 MHz: -76 dBm (MCS0), -50 dBm (MCS9)</p> <p>11ax: 20 MHz: -85 dBm (MCS0), -58 dBm (MCS11)</p> <p>11ax: 40 MHz: -82 dBm (MCS0), -54 dBm (MCS11)</p> <p>11ax: 80 MHz: -79 dBm (MCS0), -52 dBm (MCS11)</p> <p>11ax: 160 MHz: -76 dBm (MCS0), -49 dBm (MCS11)</p> <p>11be: 20 MHz: -85 dBm (MCS0), -52 dBm (MCS13)</p> <p>11be: 40 MHz: -82 dBm (MCS0), -49 dBm (MCS13)</p>

		11be: 80 MHz: -82 dBm (MCS0), -46 dBm (MCS13) 11be: 160 MHz: -79 dBm (MCS0), -44 dBm (MCS13)
Antenna	Antenna	2.4 GHz: 2 built-in omnidirectional antennas 5 GHz: 3 built-in omnidirectional antennas
	Antenna gain (5 GHz)	4.44 dBi
	Antenna gain (2.4 GHz)	3.23 dBi
Port Specifications	Number of 10/100/1000/2500BASE-T ports	1
	Maximum rate of the LAN port	2500 Mbps
	Reset button	1
	LEDs	1 x system status LED
Power Supply and Consumption	Power supply	<ul style="list-style-type: none"> ● DC power adapter ● PoE/PoE+ Note: If both the DC power adapter and PoE/PoE+ are available for power supply, the DC power adapter is preferred.
	Local power supply	Yes, one DC power connector (12 V, 1.5 A)
	Dimensions of the DC connector	Outer diameter: 5.5 mm (0.22 in.) Inner diameter: 2.1 mm (0.08 in.) Depth: 10 mm (0.39 in.)
	PoE In standard	IEEE 802.3af (PoE) IEEE 802.3at (PoE+)
	Maximum power consumption	14 W
Dimensions and Weight	Product dimensions (diameter x height)	Ø195 mm x 41 mm (Ø7.68 in. x 1.61 in.) (excluding the mounting bracket)
	Package dimensions (W x D x H)	243 mm x 233 mm x 67 mm (9.57 in. x 9.17 in. x 2.64 in.)
	Color	White

	Weight	≤ 0.6 kg (1.32 lbs.) (without packaging materials)
	Shipping weight	≤ 1 kg (2.2 lbs.)
Environment and Reliability	Operating temperature	0°C to 40°C (32°F to 104°F)
	Storage temperature	−40°C to +70°C (−40°F to +158°F)
	Operating humidity	5% RH to 95% RH (non-condensing)
	Storage humidity	5% RH to 95% RH (non-condensing)
	Mounting options	Ceiling/Wall
	IP rating	IP41
	Surge protection	Ethernet port: ±2 kV for common mode
Certification and Regulatory Compliance	MTBF	400,000 hours
	RoHS	Yes
	Certification	CE, CB, ISED, cTUVus

Warning

In a domestic environment, this product may cause radio interference, in which case the user may be required to take adequate measures.

1.5 Power Supply

The RG-RAP72 supports DC and PoE power supply.

- When the AP is powered by a DC power adapter, the power adapter should have a voltage of 12 V and a current of 1.5 A. If you require a DC power adapter, it can be purchased separately from Ruijie.
- When the AP is powered by standard PoE, connect one end of the Ethernet cable to the LAN/2.5G/PoE port on the AP, and the other end to a PoE-capable switch or any other PoE power source equipment (PSE). For optimal performance, you are advised to use an IEEE 802.3af/at-compliant PoE power source.

Caution

- The DC input power of the DC power adapter must be greater than the actual power consumption of the AP.
 - When the AP is powered by a DC power adapter, you are advised to use the power adapter that comes with the Ruijie device.
 - Ruijie-certified PoE adapters are recommended.
-

1.6 Cooling

The RG-RAP72 adopts a fanless design with natural cooling.

 **Caution**

Ensure that there is sufficient space around the AP for heat dissipation.

2 Preparing for Installation

2.1 Safety Guidelines

Note

- To avoid personal injury or equipment damage, review the safety guidelines in this chapter before you begin the installation.
 - The following safety guidelines may not include all the potentially hazardous situations.
-

2.1.1 General Safety Guidelines

- Do not expose the equipment to high temperature, dusts, or harmful gases. Do not install the equipment in an inflammable or explosive environment. Keep the equipment away from EMI sources such as large radar stations, radio stations, and substations. Do not subject the equipment to unstable voltage, vibration, and noises.
 - The installation site should be dry. Do not install the equipment in a place near the sea. Keep the equipment at least 500 meters away from the ocean and do not face it towards the sea breeze.
 - The installation site should be free from water flooding, seepage, dripping, or condensation. The installation site should be selected according to network planning, communications equipment features, and considerations such as climate, hydrology, geology, earthquake, electrical power, and transportation.
-

Caution

Always install and remove the equipment according to the installation procedures outlined in this document.

2.1.2 Chassis-Lifting Guidelines

- After the equipment is installed, avoid handling it frequently.
- Cut off all power supplies and unplug all power cords before moving or handling the equipment.

2.1.3 Electrical Safety Guidelines

Warning

- Improper or incorrect electric operations may cause a fire, electric shock, and other accidents, and lead to severe and fatal personal injury and device damage.
 - Direct or indirect contact with high voltage or mains power supply through wet objects may cause fatal dangers.
-

- Observe local regulations and specifications during electric operations. Only personnel with relevant qualifications can perform such operations.
- Check whether there are potential risks in the work area. For example, check whether the ground is wet.
- Find out the position of the indoor emergency power switch before installation. Cut off the power switch in case of accidents.

- Make sure that the equipment is powered off when you cut off the power supply.
- Do not place the equipment in a damp/wet location. Do not let any liquid enter the chassis.
- Keep the equipment far away from grounding or lightning protection devices for power equipment.
- Keep the equipment away from radio stations, radar stations, high-frequency high-current devices, and microwave ovens.

2.2 Site Requirements

Install the equipment indoors to ensure its normal operation and prolonged service life. The installation site must meet the following requirements.

2.2.1 Bearing Requirements

Ensure that the installation position is sturdy enough to support the weight of the equipment and its accessories.

2.2.2 Space Requirements

- The equipment should be installed in an open environment if possible. If the environment is enclosed, confirm that a good ventilation and heat dissipation system is available.
- Ensure that the installation location is suitable for the RG-RAP72, leaving sufficient space on the front, back, left, and right sides for heat dissipation.

2.2.3 Ventilation Requirements

The RG-RAP72 dissipates heat naturally. Therefore, certain space needs to be reserved around the equipment for heat dissipation.

2.2.4 Temperature/Humidity Requirements

To ensure that the RG-RAP72 works properly and has a long service life, maintain a proper temperature and humidity in the operating environment. The operating environment with too high or too low temperature and humidity for a long period of time may damage the equipment.

- In an environment with high relative humidity, the insulating material may have poor insulation or even leak electricity. Sometimes high humidity may causes changes in the mechanical properties and causes rusting of metal parts.
- In an environment with low relative humidity, static electricity is prone to occur and damage the internal circuits of the equipment.
- Too high temperatures can accelerate the aging of insulation materials, greatly reducing the reliability of the equipment and severely affecting its service life.

The following table lists the temperature and humidity requirements.

Table 2-1 Temperature/Humidity Requirements

Operating Temperature	Operating Humidity
0°C to 40°C (32°F to 104°F)	5% RH to 95% RH (non-condensing)

2.2.5 Cleanliness Requirements

Dust poses a major threat to the equipment. The indoor dust takes on a positive or negative static electric charge when falling on the switch, causing poor contact of the metallic joint. Such electrostatic adhesion may occur more easily when the relative humidity is low, not only affecting the service life of the equipment, but also causing communication faults. The following table describes the requirements for the dust content and granularity in the machine room.

Table 2-2 Requirements for Dust

Dust	Unit	Content
Dust particles (diameter $\geq 0.5 \mu\text{m}$)	Particles/m ³	$\leq 3.5 \times 10^6$
Dust particles (diameter $\geq 5 \mu\text{m}$)	Particles/m ³	$\leq 3.5 \times 10^4$

Apart from dust, the salt, acid, and sulfide in the air in the machine room must meet strict requirements. These harmful substances will accelerate metal corrosion and component aging. Therefore, the machine room should be properly protected against the intrusion of harmful gases, such as sulfur dioxide, hydrogen sulfide, nitrogen dioxide, and chlorine gas. The following table lists limit values for harmful gases.

Table 2-3 Requirements for Gases

Gas	Average (mg/m ³)	Maximum (mg/m ³)
Sulfur dioxide (SO ₂)	0.2	1.5
Hydrogen sulfide (H ₂ S)	0.006	0.03
Nitrogen dioxide (NO ₂)	0.04	0.15
Ammonia gas (NH ₃)	0.05	0.15
Chlorine gas (Cl ₂)	0.01	0.3

Note

Average refers to the average value of harmful gases measured in one week. Maximum refers to the upper limit of harmful gases measured in one week, and the maximum value cannot last for more than 30 minutes every day.

2.2.6 ESD Requirements

This equipment is engineered with stringent anti-static measures during circuit design. However, excessive static electricity can still potentially damage the printed circuit board. Static electricity in the communication network connected to the equipment primarily comes from two sources:

- Outdoor high-voltage power lines, lightning, and other external electric fields; and
- Internal systems such as flooring materials and the internal structure of the equipment.

To prevent damage from static electricity, pay attention to the following:

- Keep the indoor installation environment clean and free of dust; and
- Maintain appropriate temperature and humidity conditions.

2.2.7 EMI Requirements

- Keep the equipment far away from grounding or lightning protection devices for power equipment.
- Keep the equipment away from radio stations, radar stations, high-frequency high-current devices, and microwave ovens.

2.3 Tools

Common Tools	Phillips screwdriver, cables, fastening bolts, diagonal plier, cable ties
Special Tools	Anti-ESD gloves, wire stripper, crimper, RJ45 crimping plier, wire cutter, and waterproof tape
Meters	Multimeter and bit error rate tester (BERT)

Note

The equipment is delivered without a toolkit. Prepare the preceding tools by yourself.

3 Installing the AP

The AP is required to be fixed indoors.

 **Caution**

Before installing the equipment, ensure that guidelines and requirements in Chapter 2 have been met.

3.1 Before You Begin

Carefully plan and arrange the installation position, networking mode, power supply, and cabling before installation. Confirm the following requirements before installation:

- The installation site provides sufficient space for proper ventilation.
- The installation site meets the temperature and humidity requirements of the AP.
- The power supply and required current are available in the installation site.
- The selected power supply modules meet the system power requirements.
- The installation site meets the cabling requirements of the AP.
- The installation site meets the site requirements of the AP.
- The customized AP meets the client-specific requirements.

3.2 Safety Precautions During Installation

To ensure the normal operation and prolonged service life of the AP, observe the following safety precautions:

- Do not power on the AP during installation.
- Place the AP in a well-ventilated environment.
- Do not subject the AP to high temperatures.
- Keep the AP away from high-voltage power cables.
- Install the AP indoors.
- Do not expose the AP to a thunderstorm or strong electric field.
- Keep the AP clean and dust-free.
- Cut off the power switch before cleaning the AP.
- Do not wipe the AP with a damp cloth.
- Do not wash the AP with liquid.
- Do not open the enclosure when the AP is working.
- Fasten the AP tightly.

3.3 Installing the AP

i Note

- For indoor environments, ceiling mounting is preferred because it offers a broader coverage area than wall mounting.
- This installation guide is for reference only. The actual installation procedure may differ depending on the specific product.

3.3.1 Mounting the AP on a Ceiling or Wall

- (1) Drill holes in the ceiling or wall using the alignment sticker.

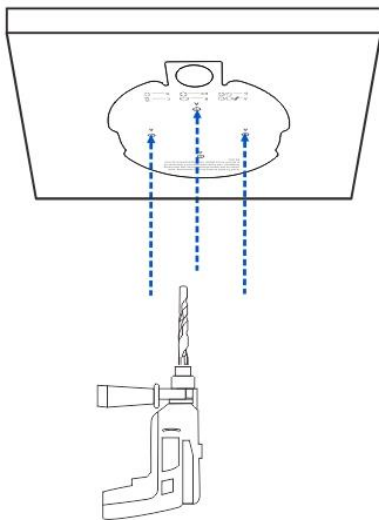

- (2) Secure the mounting bracket to the ceiling or wall using plastic expansion anchors ($\varnothing 9 \times 25.4$ mm) and cross pan head screws (ST4.2 x 20 mm).

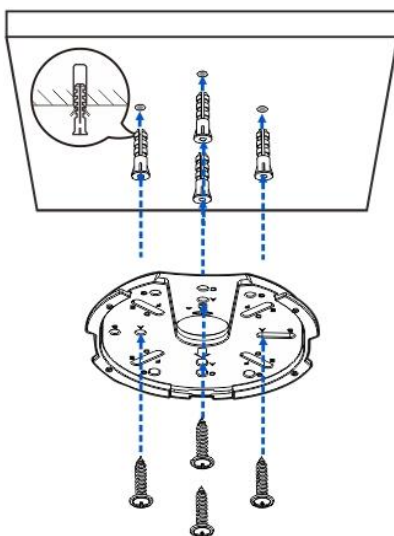

⚠ Caution

The plane deviation of the wall in the installation area should be within 2 mm (0.08 in.), and the recommended torque for installation is 4kgf.cm. In case of an uneven installation area, mount the AP on a protruding wall using screws.

(3) Connect cables according to the actual topology. The following describes how to connect cables on the AP side.

- Ethernet cable: Connect one end of the Ethernet cable to the LAN/2.5G/PoE port (supporting PoE input) on the rear of the AP.
- DC power cord: When DC power supply is used, connect one end of the power cord to the 12 V DC power connector on the rear of the AP.

The cables can be routed either through concealed wiring or exposed wiring methods.

o Concealed wiring:

- a Route the cable through the ceiling or wall and connect it to the Ethernet port on the rear of the device.

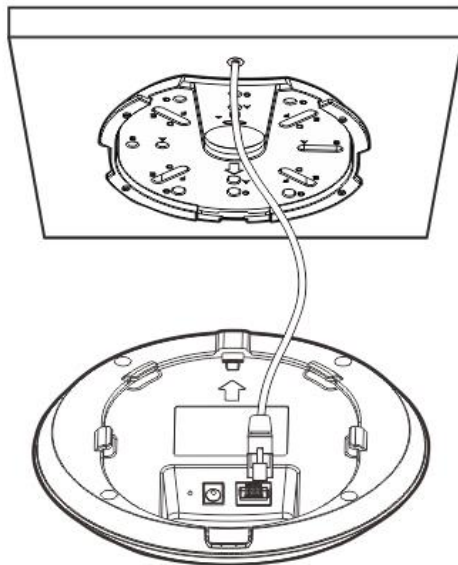

- b Align the slots on the rear of the AP with the square feet on the mounting bracket, and slide the AP into the mounting bracket slowly to ensure that the AP is secured.

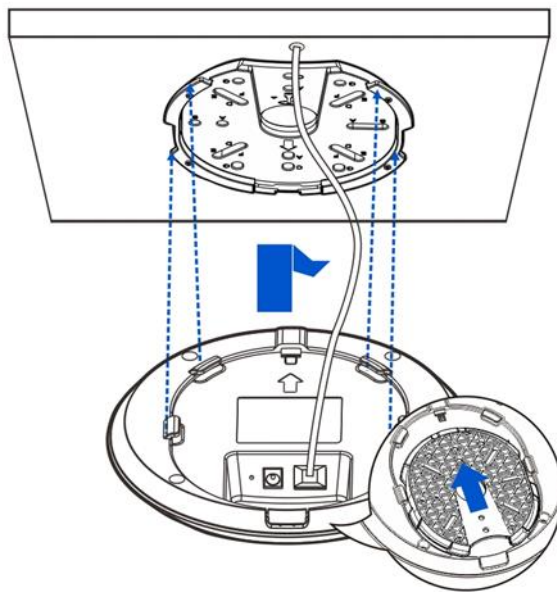

c The installation is complete.

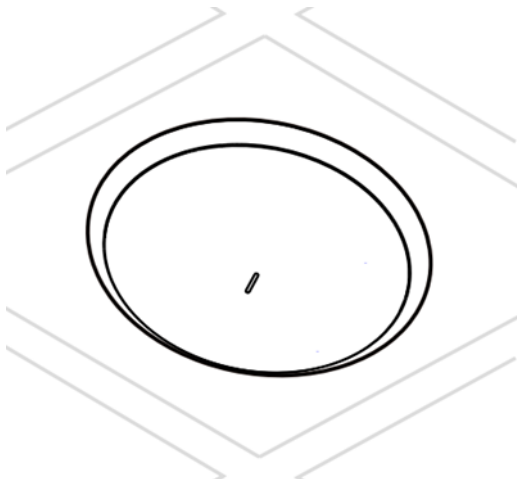

o Exposed wiring:

a Remove the knockout from the cable inlet opening and route the cable through it.

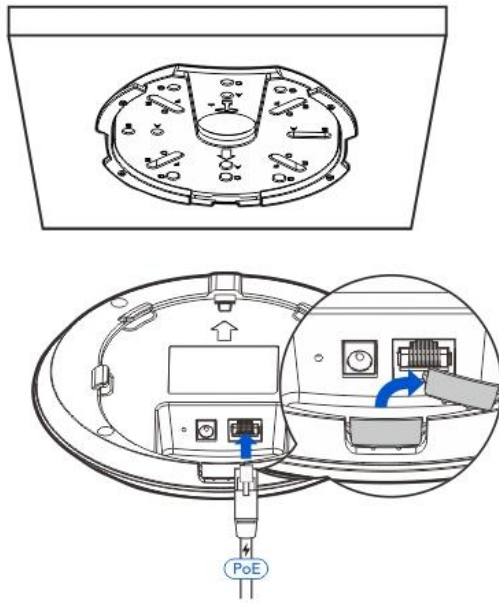

- b Align the slots on the rear of the AP with the square feet on the mounting bracket, and slide the AP into the mounting bracket slowly to ensure that the AP is secured.

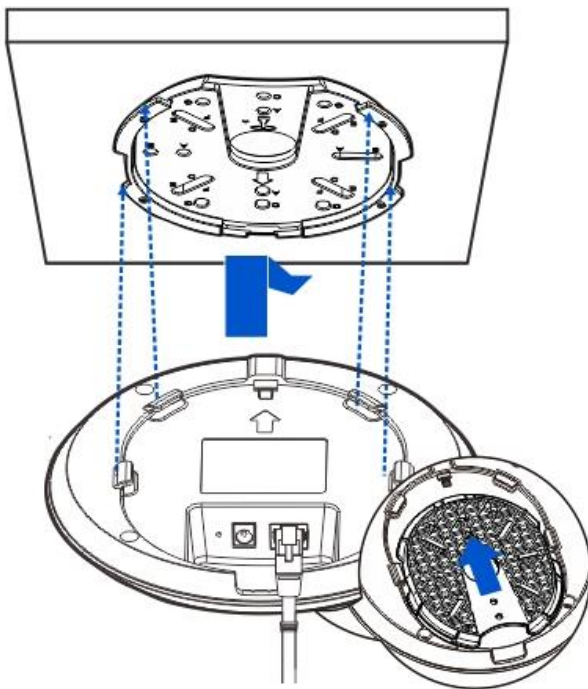

- c The installation is complete.

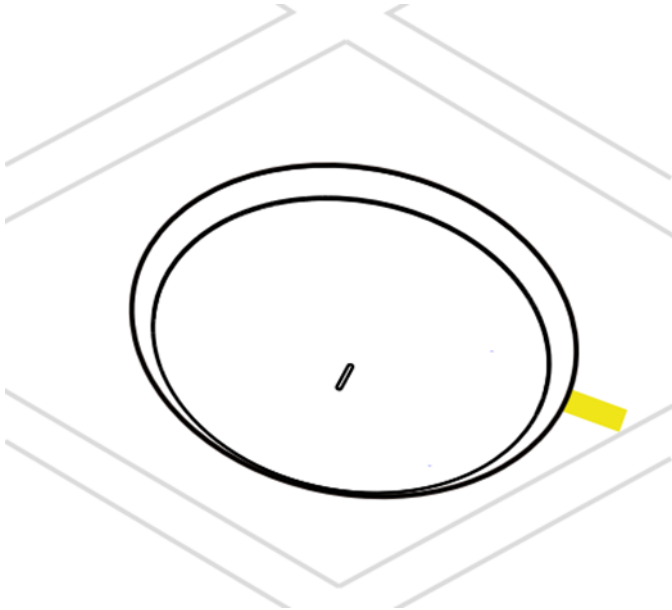

⚠ Caution

- Before securing the AP to the mounting bracket, connect the cables first.
 - Align the slots on the rear of the AP and slid them into the square feet on the mounting bracket. Do not press the slots into the square feet by force.
 - After the installation is complete, check whether the AP is secured.
-

3.3.2 Mounting the AP in an 86 mm Junction Box

- (1) Remove the cover of the 86 mm junction box.

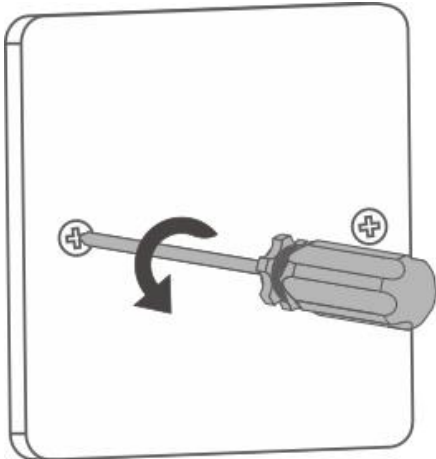

- (2) Align the mounting holes of the bracket with the screw holes in the 86 mm junction box. Then, secure the bracket to the junction box using cross pan head screws (ST4.2 x 20 mm).

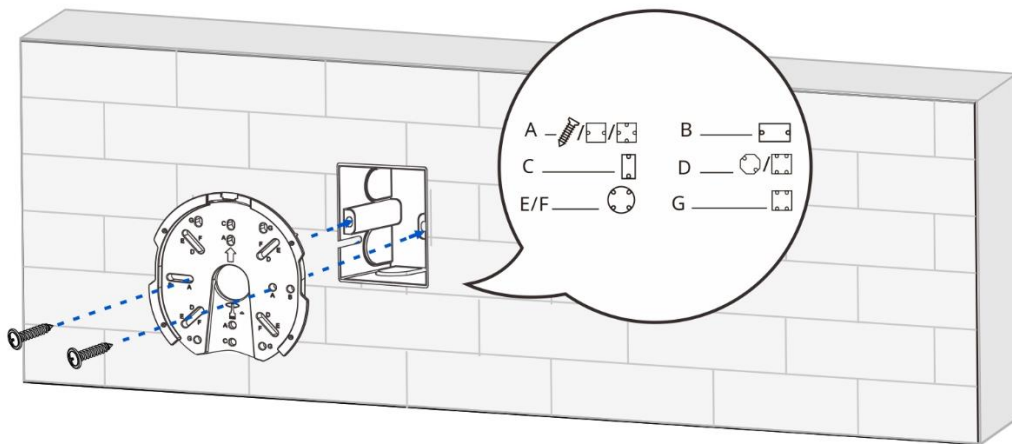

Note

Select a mounting bracket with different hole combinations based on junction box specifications.

(3) Connect cables according to the actual topology. The following describes how to connect cables on the AP side.

- Ethernet cable: Connect one end of the Ethernet cable to the LAN/2.5G/PoE port (supporting PoE input) on the rear of the AP.
- DC power cord: When DC power supply is used, connect one end of the power cord to the 12 V DC power connector on the rear of the AP.

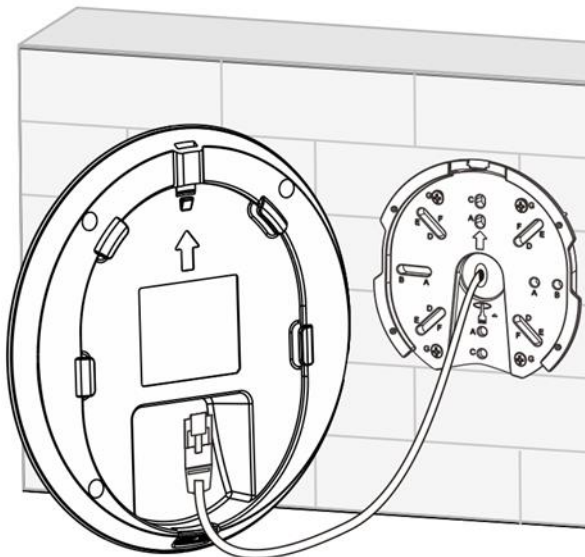

(4) Align the slots on the rear of the AP with the square feet on the mounting bracket, and slide the AP into the mounting bracket slowly to ensure that the AP is secured.

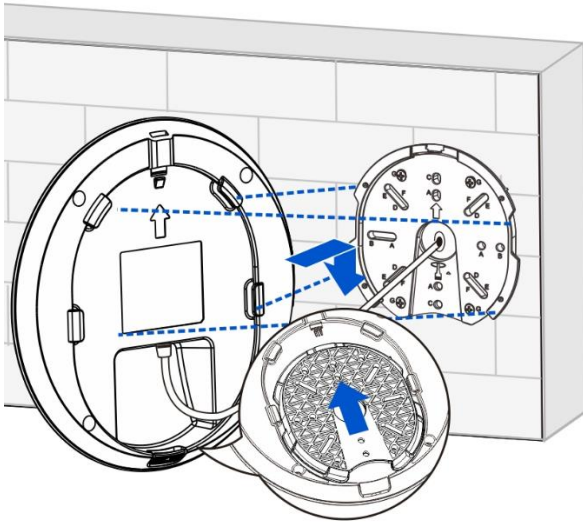

(5) The installation is complete.

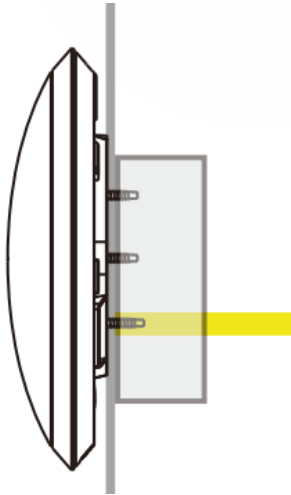

⚠ Caution

- Before securing the AP to the mounting bracket, connect the cables first.
 - Align the slots on the rear of the AP and slid them into the square feet on the mounting bracket. Do not press the slots into the square feet by force.
 - After the installation is complete, check whether the AP is secured.
-

3.4 Removing the AP

(1) Insert the key to the lock into the reserved slot.

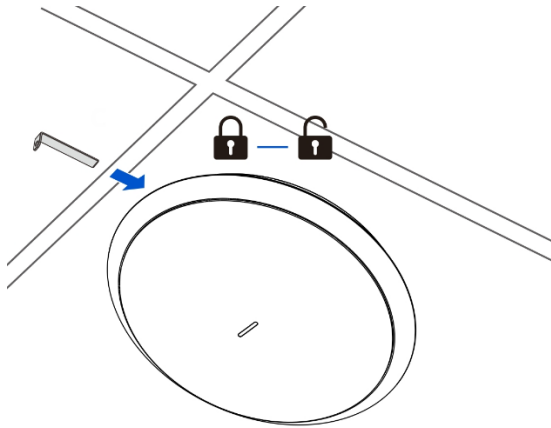

(2) Slide down the AP as indicated by the arrow.

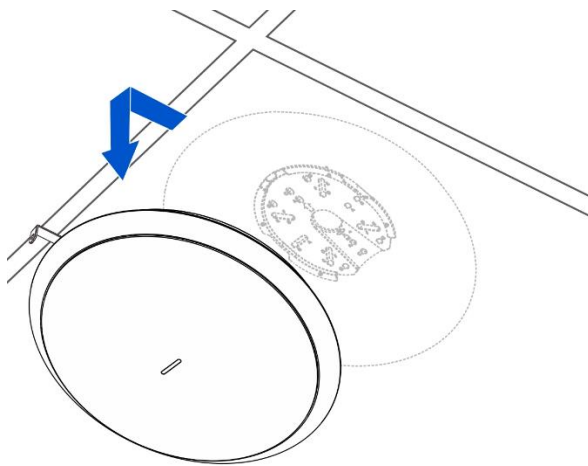

3.5 Connecting Cables

Connect twisted pairs with the LAN/PoE port on the AP. See [7.1 Connectors and Media](#) for supported wiring of twisted pairs.

⚠ Caution

- Avoid a small bend radius at the connector.
 - You are advised not to use Ethernet cables with protective caps for the RG-RAP72, as they complicate the assembly of the Ethernet cables.
-

3.6 Bundling Cables

Precautions

- Bundle the cable in a visually pleasing way.
- Bend twisted pairs naturally or to a large radius close to the connector.
- Do not over-tighten the twisted pair bundle as it may reduce the cable life and performance.

Bundling Steps

- (1) Bundle the hanging part of the twisted pairs using cable ties and lead them to the LAN/PoE port of the AP by convenience.
- (2) Fasten the twisted pair cables to the cable trough of the mounting bracket.
- (3) Extend the twisted pair cables under the AP and route them in a straight line.

3.7 Verifying the Installation

- Verify that the AP is securely fastened.
- Verify that the twisted pair cable matches the port type.
- Verify that the cables are properly bundled.
- Verify that the PSE is IEEE 802.3af/at-compliant.

4 Commissioning

4.1 Setting Up the Configuration Environment

After powering on the AP through a DC power adapter or a PSE, ensure that the power cord is properly connected and meets safety requirements.

4.2 Powering on the AP

4.2.1 Checklist Before Power-On

- The power cord is properly connected.
- The power voltage meets the requirement.

4.2.2 Checklist After Power-on

- Verify the LED status.
- After the AP is powered on, verify that the SSID can be searched by a mobile phone or other wireless devices.

4.3 Troubleshooting Power Supply Failures

You can determine whether there is a power system failure by checking the LED status on the front panel of the RG-RAP72. For the LED status description, see [Table 1-2 LEDs](#). Perform the following checks in the case of any abnormality:

- Verify that the AP is properly powered.
- Verify that the Ethernet port is correctly connected.

 Note

If the AP cannot be powered on after all the preceding items are verified, contact your local distributor or technical support.

5 Monitoring and Maintenance

5.1 Monitoring

When the RG-RAP72 is operating, you can monitor the device running status by observing the LED. For LED status description, see [Table 1-2 LEDs](#).

5.2 Hardware Maintenance

If the hardware is faulty, contact your local distributor.

6 Common Troubleshooting

6.1 Troubleshooting Flowchart

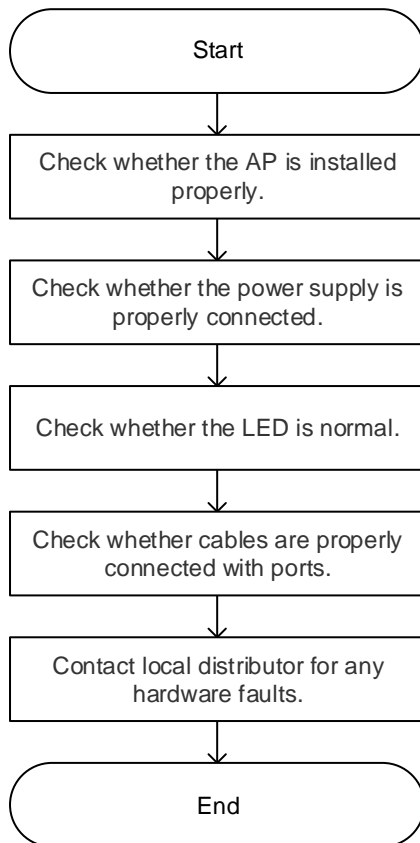

6.2 Common Faults

6.2.1 The LED is Off After the AP is Powered On

- If you use a PoE power supply, verify that the PSE is IEEE 802.3at-compliant, and then verify that the cable is connected properly.
- If you use a power adapter, verify that the power adapter is connected with an active power outlet, and then verify that the power adapter works properly.

6.2.2 Ethernet Port Is Not Working After the Ethernet Cable Is Plugged In

Verify that the device at the other end of the Ethernet cable is working properly, and then verify that the Ethernet cable is capable of providing the required data rate and is properly connected.

6.2.3 A Client Cannot Discover the AP

- (1) Verify that the AP is properly powered.
- (2) Verify that the Ethernet port is correctly connected.

- (3) Verify that the AP is correctly configured.
- (4) Move the client closer to the AP.

7 Appendix

7.1 Connectors and Media

7.1.1 10/100/1000/2.5GBASE-T Port

A 10/100/1000/2.5GBASE-T port supports four rates with auto-negotiation, and supports the automatic MDI/MDIX crossover function at these four rates.

Compliant with IEEE 802.3bz, the 2.5GBASE-T port requires Cat5e or higher 100-ohm unshielded twisted pair (UTP) or shielded twisted pair (STP) cables with a maximum distance of 100 m (328.08 ft.).

Compliant with IEEE 802.3ab, the 1000BASE-T port requires Cat5/5e or higher 100-ohm unshielded twisted pair (UTP) or shielded twisted pair (STP) cables with a maximum distance of 100 m (328.08 ft.).

The 1000/2.5GBASE-T port requires all four pairs of wires to be connected for data transmission. The following figure shows the four pairs of wires for the 1000/2.5GBASE-T port.

Figure 7-1 1000/2.5GBASE-T Twisted Pair Connections

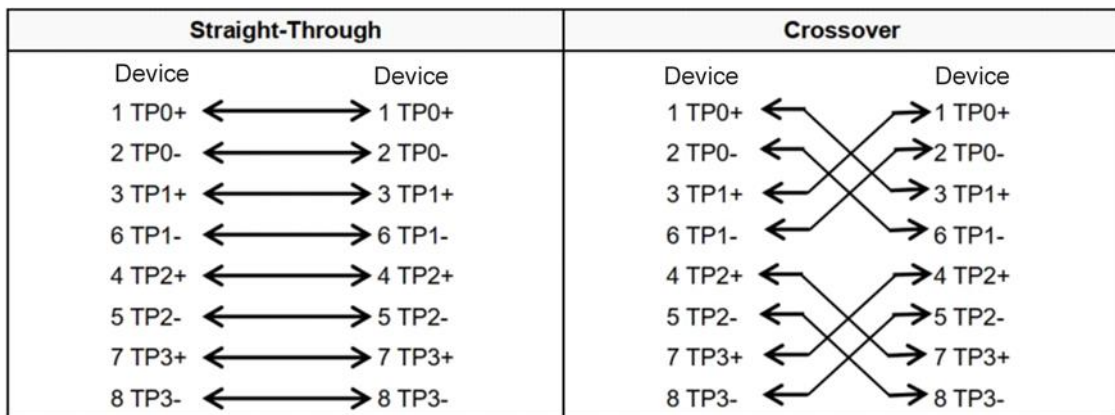

A 10BASE-T/100BASE-TX port can be interconnected using cables of the preceding specifications. For 10 Mbps, the 10BASE-T/100BASE-TX port can be connected using 100-ohm Category 3, Category 4, and Category 5 cables; for 100 Mbps, the 10BASE-T/100BASE-TX port can be connected using 100-ohm Category 5 cables with a maximum connection distance of 100 meters (328 ft.). [Table 7-1](#) lists 10BASE-T/100BASE-TX pin assignments.

Table 7-1 10BASE-T/100BASE-TX Pin Assignments

Pin	Socket	Plug
1	Input Receive Data+	Output Transmit Data+
2	Input Receive Data-	Output Transmit Data-
3	Output Transmit Data+	Input Receive Data+

6	Output Transmit Data-	Input Receive Data-
4, 5, 7, 8	Not Used	Not Used

Figure 7-2 shows feasible connections of the straight-through and crossover twisted pairs for a 10BASE-T/100BASE-TX port.

Figure 7-2 10BASE-T/100BASE-TX Twisted Pair Connections

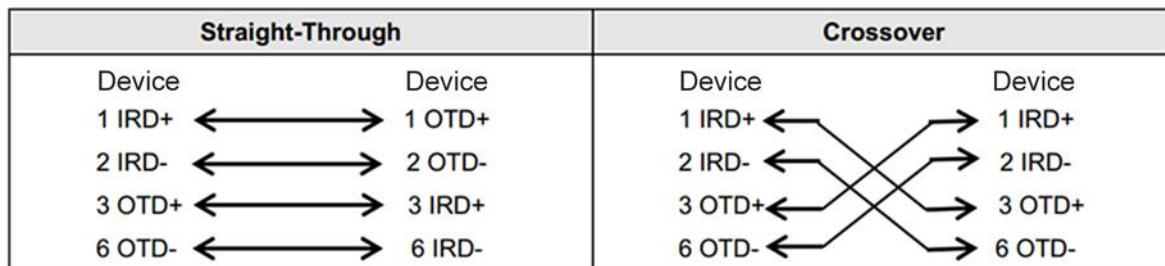

7.2 Cabling Recommendations

During installation, route cable bundles upward or downward along the sides of the rack depending on the actual situation in the equipment room. All adapted connectors should be placed at the bottom of the rack in an orderly manner, and cannot be exposed outside the rack. Power cords are routed upward or downward beside the rack close to the location of the DC power distribution box, AC socket, or surge protection box in the equipment room.

7.2.1 Requirements for the Minimum Bend Radius of Ethernet Cables

- The bend radius of a fixed power cord, Ethernet cable, or flat cable should be over five times greater than their respective diameters. The bend radius of these cables that are often bent or plugged should be over seven times greater than their respective diameters.
- The bend radius of a fixed common coaxial cable should be over seven times greater than its diameter. The bend radius of these cables that are often bent or plugged should be over 10 times greater than their respective diameters.
- The minimum bend radius of a high-speed cable, such as an SFP+ cable, should be over five times greater than its diameter. The bend radius of these cables that are often bent or plugged should be over 10 times greater than their respective diameters.

7.2.2 Precautions for Cable Bundling

- Before cables are bound, mark labels and stick them to cables wherever appropriate.
- Cables should be neatly and properly bound in the cabinet without twisting or bending, as shown in [Figure 7-3](#).

Figure 7-3 Bundling Cables

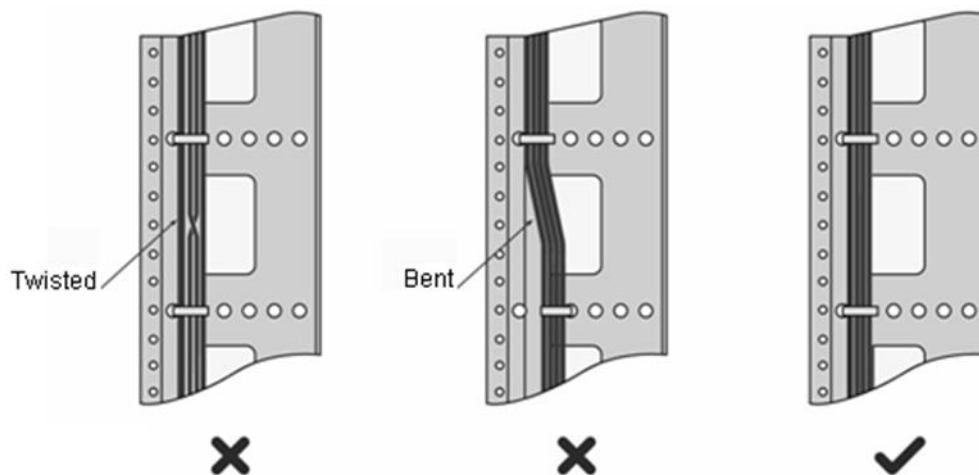

- Route and bundle power, signal, ground cables separately. Mixed bundling is not allowed. When the cables are close to each other, crossover cabling is recommended. In the case of parallel cabling, maintain a minimum distance of 30 mm (1.18 in.) between power cords and signal cables.
- The cable management brackets and cabling troughs inside and outside the rack should be smooth without sharp corners.

- The metal holes traversed by cables should have a smooth and fully rounded surface or an insulated lining.
- Use cable ties to bundle up cables properly. Do not connect two or more cable ties to bundle up cables.
- After bundling up cables with cable ties, cut off the remaining part. The cut should be smooth and trim without sharp corners, as shown in [Figure 7-4](#).

Figure 7-4 Cutting off an Excess Cable Tie

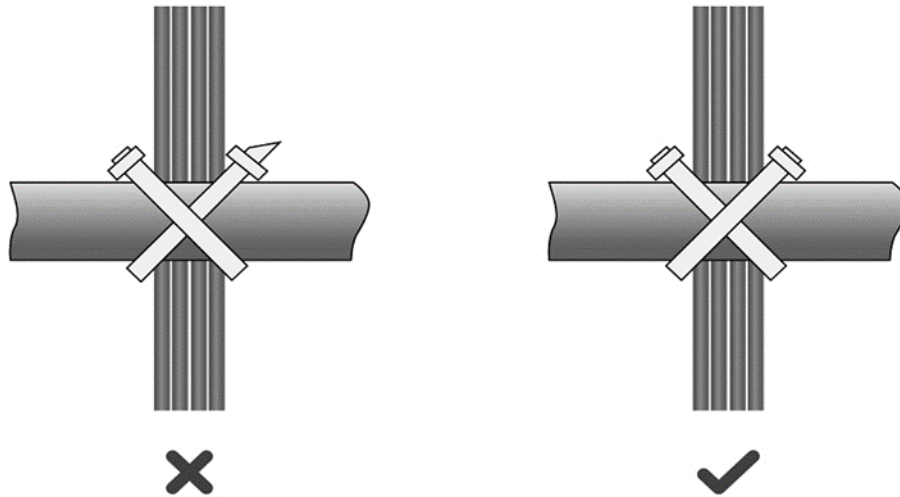

- When cables need to be bent, bind them first, but do not tie cable ties within the bend. Otherwise, stress may be generated on the cables and causes the wires inside to break, as shown in [Figure 7-5](#).

Figure 7-5 Binding Cables

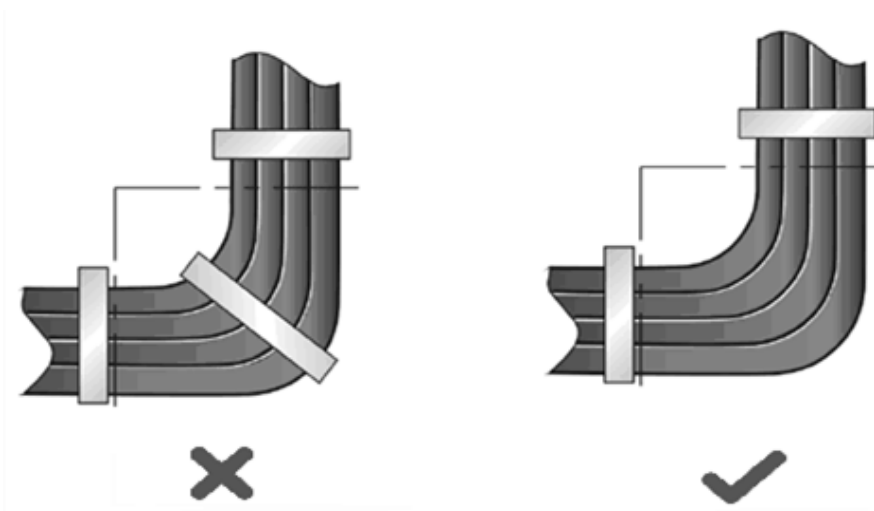

- Cables not to be assembled or the remaining parts of cables should be folded and placed in a proper position of the rack or cable trough. The proper position refers to a position that does not affect the device running or damage the equipment or cables.
- Do not bind power cords to the guide rails of moving parts.
- The power cords connecting moving parts such as door grounding cables should be reserved with some excess after being assembled. This can avoid tension or stress on power cords. After the moving part arrives

at the position of the power cords, the remaining cable part should not touch heat sources, sharp corners, or sharp edges. If heat sources cannot be avoided, high-temperature cables should be used.

- When using screw threads to secure a cable lug, ensure that the bolt or screw is properly tightened and take measures to prevent it from loosening, as shown in [Figure 7-6](#).

Figure 7-6 Fastening Cable Lugs

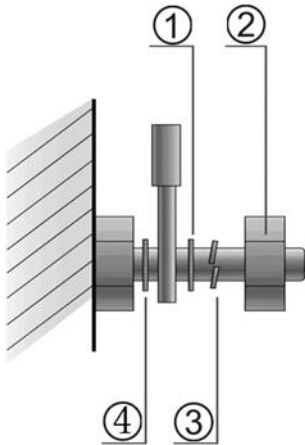

1. Flat washer	3. Spring washer
2. Nut	4. Flat washer

- Hard power cords should be fastened in the terminal connection area to prevent stress on terminal connection and cable.
- Do not use self-tapping screws to fasten terminals.
- Power cords of the same type and in the same cabling direction should be bundled up into cable bunches, with cables in cable bunches clean and straight.
- Bundle up cables by using cable ties.

Cable Bunch Diameter	Distance between Every Binding Point
10 mm (0.39 in.)	80 mm to 150 mm (3.15 in. to 5.91 in.)
10 mm to 30 mm (0.39 in. to 1.18 in.)	150 mm to 200 mm (5.91 in. to 7.87 in.)
30 mm (1.18 in.)	200 mm to 300 mm (7.87 in. to 11.81 in.)

- No knot is allowed in cabling or bundling.
- For wiring terminal blocks (such as air switches) of the cord end terminal type, the metal part of the cord end terminal should not be exposed outside the terminal block when assembled.